

Diameter:

200 mm

R09_-2025_-2M-1511



Nominal data according to standard EN 60335:

Phase	1~
Nominal voltage	230 V
Frequency	50/60 Hz
Rated power input	45/55 W
Rated current	0.21/0.24 A
Rated speed	2580/2850 RPM
Min. ambient temperature	-30 °C
Max. ambient temperature	70 °C
Sound power level A weighted	66/69 dB (A)
Condensator	1.5 µF/450 V
Connection	cabl
Insulation class	155
Protection class	IP44

Is not subject to the EU regulation 327/2011.

Power input lower than 125 W.

Fan with guard grill

Airflow Direction	Type	Code	Weight (kg)
Sucking	R09R-2025A-2M-1511	0309-4-0190	1.6
Blowing	R09R-2025P-2M-1511	0309-4-0214	

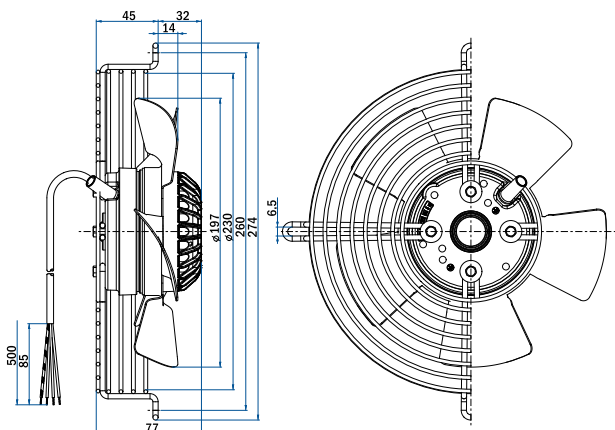

Aerodynamic characteristic

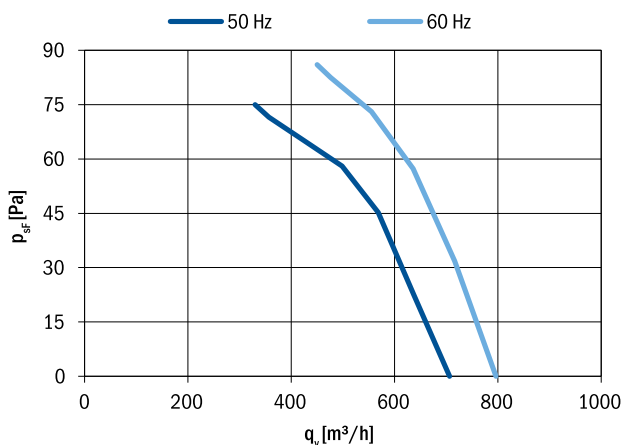

Fan characteristic measured in full bell mouth with guard grill.

Fan with plate

Airflow Direction	Type	Code	Weight (kg)
Sucking	R09P-2025A-2M-1511	On request	2.3
Blowing	R09P-2025P-2M-1511	0309-4-0171	

Fan without guard grill

Airflow Direction	Type	Code	Weight (kg)
Sucking	R09E-2025A-2M-1511	On request	
Blowing	R09E-2025P-2M-1511	On request	

General notes

Connection diagrams:		
Sucking	0301-1-0026	See section
Blowing	0301-1-0042	Connection diagrams
Guard grills & wall-plates	See section Accessories	
Standards compliance	See introduction page	