

## UNJ6226ZX

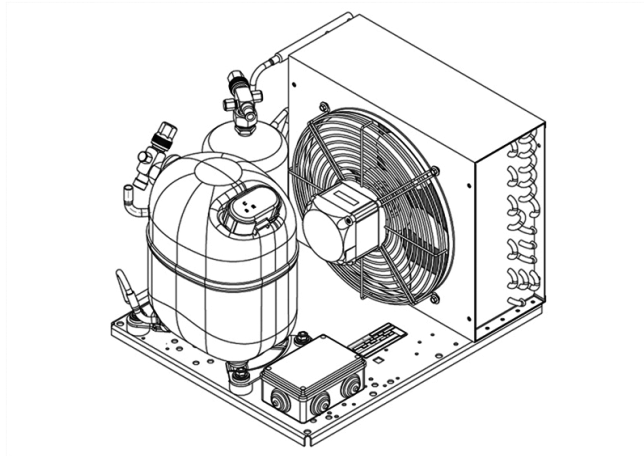

CE

**ENGINEERING CODE**  
546EM5603AA

**REFRIGERANT**  
R-513A

**POWER SUPPLY**  
380-420 V 50 Hz

**APPLICATION**  
HBP

**MOTOR TYPE**  
3PH

**STANDARD**  
EN13215\_RG20

**COOLING CAPACITY**  
1630 W

**EFFICIENCY**  
1.74 W/W

## DATA

## GENERAL DATA

Model	UNJ6226ZX
-------	-----------

## ELECTRICAL DATA

Locked Rotor Amperage (LRA)	13.70 A
-----------------------------	---------

Rated Load Amperage (RLA)	2.75 A
---------------------------	--------

Maximum Overcurrent Protection (MOP)	6.19 A
--------------------------------------	--------

Minimum Current Ampacity (MCA)	3.4 A
--------------------------------	-------

## ACCESSORIES

Discharge valve	SOLDER 3/8"	2110049
-----------------	-------------	---------

Suction valve	SOLDER 5/8"	2110054
---------------	-------------	---------

## CONDENSING COMPONENTS

Compressor	NJ6226ZX	M/HBP
------------	----------	-------

Condenser	3R12T	2451140
-----------	-------	---------

Refrigerant	R-134a
-------------	--------

Expansion Device	C-V
------------------	-----

Fan Blade Diameter	275 mm
--------------------	--------

Fankit	34W/400V 275/31	1996582
--------	-----------------	---------

## MECHANICAL DATA

Air Flow	640 m <sup>3</sup> /h
Height	324 mm
Receiver	2.3 L
Shaft Power	34 W
Weight	37 Kg
Width	410 mm
Length	481 mm

## PERFORMANCE

### TESTED CONDITIONS

Tested Refrigerant	R-513A
Tested Application	HBP
Tested Standard	EN13215_RG20

### RATED POINTS

Ambient Temperature °C	Evaporating Temperature °C	Cooling Capacity W	Efficiency W/W	Consumo de Potencia W
32	-10	1630	1.74	937

Test Condition: Subcooling 3 K, Return Gas 20 °C.

### PERFORMANCE CURVE

Ambient Temperature 25°C

Evaporating Temperature °C	Cooling Capacity W	Efficiency W/W	Consumo de Potencia W
-15	1464	1.82	805
-5	2077	2.00	1036
0	2384	2.03	1173
5	2843	2.19	1296
10	3569	2.57	1388

Test Condition: Subcooling 3 K, Return Gas 20 °C.

### PERFORMANCE CURVE

Ambient Temperature 32°C

Evaporating Temperature °C	Cooling Capacity W	Efficiency W/W	Consumo de Potencia W
-15	1339	1.62	828
-5	1853	1.73	1071
0	2120	1.75	1210
5	2546	1.91	1335
10	3245	2.28	1425

Test Condition: Subcooling 3 K, Return Gas 20 °C.

## PERFORMANCE CURVE

Ambient Temperature 43°C

Evaporating Temperature °C	Cooling Capacity W	Efficiency W/W	Consumo de Potencia W
-15	1123	1.28	879
-5	1574	1.39	1135
0	1824	1.43	1276
5	2243	1.60	1399

Test Condition: Subcooling 3 K, Return Gas 20 °C.

## ENVELOPE

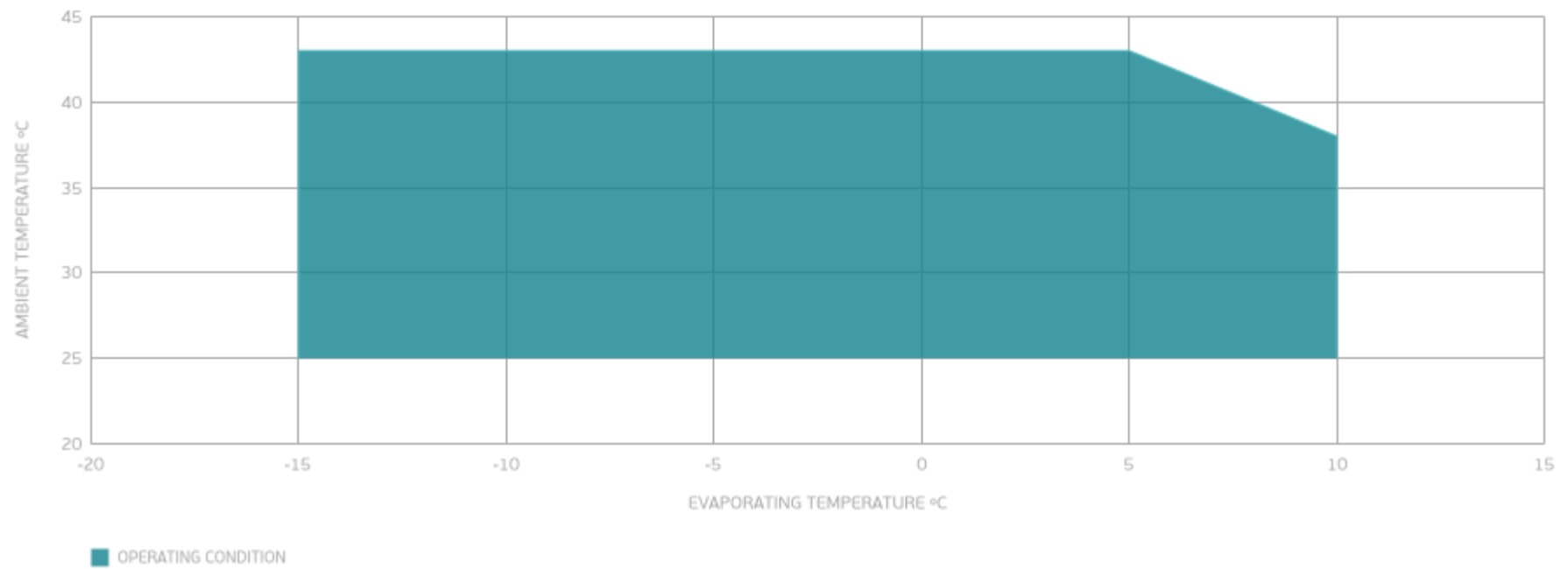

## EXTERNAL DIMENSIONS

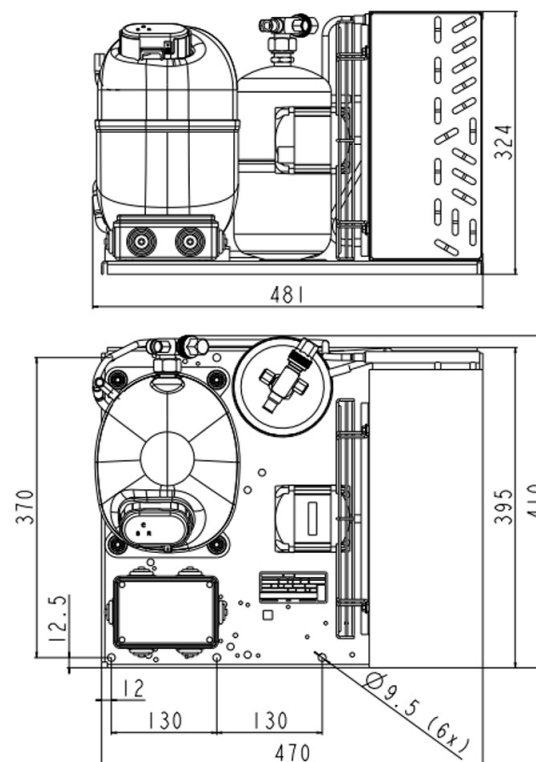

WIRING DIAGRAM

