

UNEK6210Z

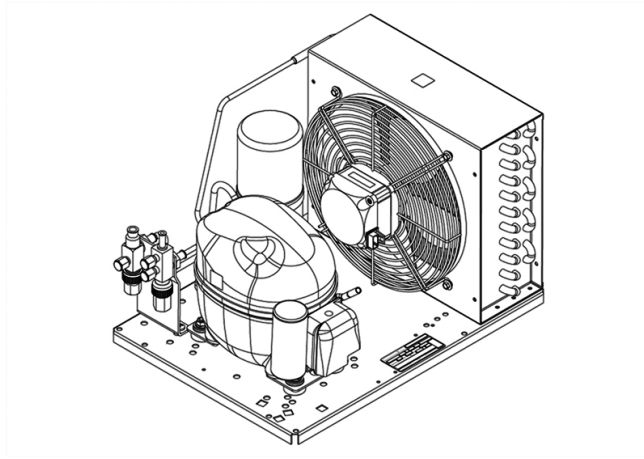

CE

ENGINEERING CODE
558BA8212AA

REFRIGERANT
R-513A

POWER SUPPLY
220-240 V 50 Hz

APPLICATION
HBP

MOTOR TYPE
CSIR

STANDARD
EN13215_RG20

COOLING CAPACITY
613 W

EFFICIENCY
1.47 W/W

DATA

GENERAL DATA

Model	UNEK6210Z
-------	-----------

ELECTRICAL DATA

Locked Rotor Amperage (LRA)	16.10 A
-----------------------------	---------

Rated Load Amperage (RLA)	3.30 A
---------------------------	--------

Maximum Overcurrent Protection (MOP)	7.42 A
--------------------------------------	--------

Minimum Current Ampacity (MCA)	4.1 A
--------------------------------	-------

ACCESSORIES

Discharge valve	FLARE 1/4"	2110085
-----------------	------------	---------

Suction valve	FLARE 3/8"	2110059
---------------	------------	---------

CONDENSING COMPONENTS

Compressor	NEK6210Z	M/HBP
------------	----------	-------

Condenser	3R11T	2451206
-----------	-------	---------

Refrigerant	R-134a
-------------	--------

Expansion Device	C-V
------------------	-----

Fan Blade Diameter	254 mm
--------------------	--------

Fankit	16W 254/28/5B	1996579
--------	---------------	---------

MECHANICAL DATA

Air Flow	595 m ³ /h
Height	296 mm
Receiver	1.1 L
Shaft Power	16 W
Weight	22 Kg
Width	340 mm
Length	465 mm

PERFORMANCE

TESTED CONDITIONS

Tested Refrigerant	R-513A
Tested Application	HBP
Tested Standard	EN13215_RG20

RATED POINTS

Ambient Temperature °C	Evaporating Temperature °C	Cooling Capacity W	Efficiency W/W	Consumo de Potencia W
32	-10	613	1.47	416

Test Condition: Subcooling 3 K, Return Gas 20 °C.

PERFORMANCE CURVE

Ambient Temperature 25°C

Evaporating Temperature °C	Cooling Capacity W	Efficiency W/W	Consumo de Potencia W
-15	558	1.52	366
-5	808	1.80	449
0	944	1.91	495
5	1087	2.00	544
10	1236	2.07	596

Test Condition: Subcooling 3 K, Return Gas 20 °C.

PERFORMANCE CURVE

Ambient Temperature 32°C

Evaporating Temperature °C	Cooling Capacity W	Efficiency W/W	Consumo de Potencia W
-15	505	1.35	376
-5	729	1.58	460
0	852	1.68	507
5	984	1.77	557
10	1123	1.84	610

Test Condition: Subcooling 3 K, Return Gas 20 °C.

PERFORMANCE CURVE

Ambient Temperature 43°C

Evaporating Temperature °C	Cooling Capacity W	Efficiency W/W	Consumo de Potencia W
-15	386	0.99	391
-5	596	1.24	481
0	715	1.35	530
5	843	1.45	583

Test Condition: Subcooling 3 K, Return Gas 20 °C.

ENVELOPE

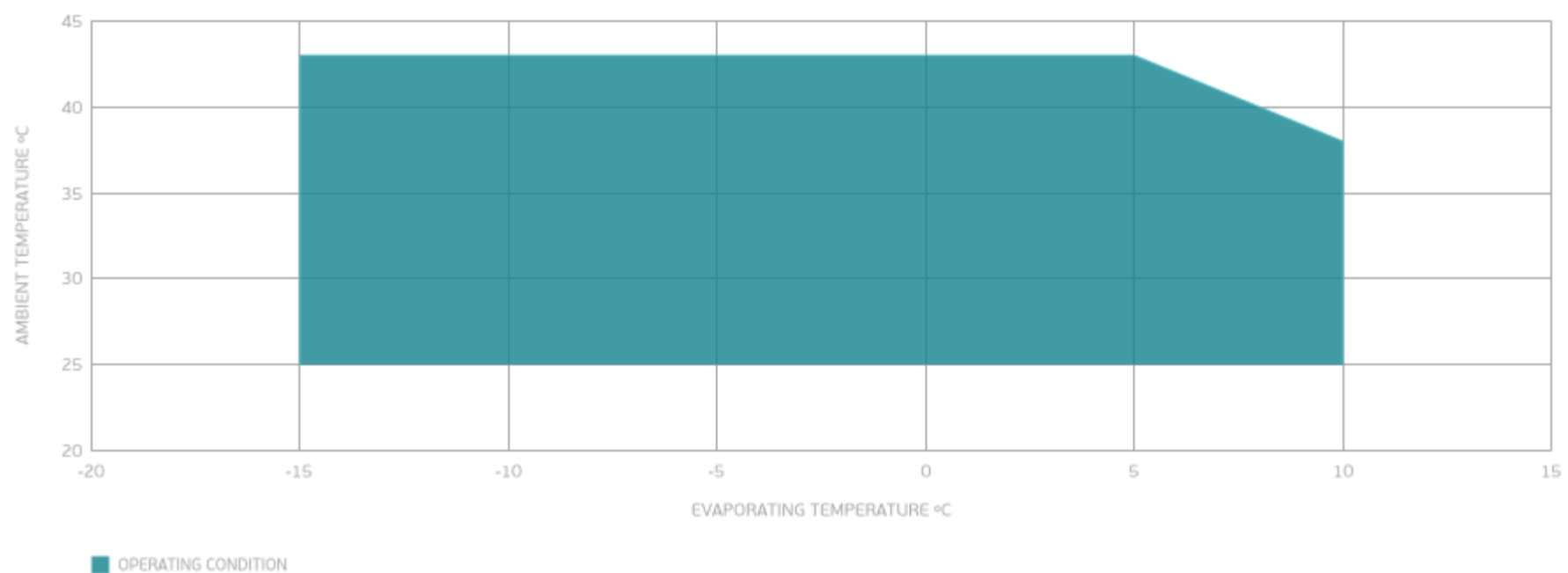

EXTERNAL DIMENSIONS

