

XR35CX Digital Controller for Medium Temperature Refrigeration Applications Installation and Operation Manual





Emerson Climate Technologies Retail Solutions
1065 Big Shanty Rd., NW Suite 100
Kennesaw, GA 30144 USA

Phone: **770-425-2724**
Fax: 770-425-9319

Table of Contents

1 INTRODUCTION	1
1.1. GENERAL WARNING	1
2 OVERVIEW	1
2.1. GENERAL DESCRIPTION	1
2.2. ORDERING CODE	1
3 CONTROLLING LOADS	2
3.1. COMPRESSOR	2
3.2. DEFROST	2
3.3. SECOND RELAY CONFIGURATION (PAR. oA1; TERM. 1-7)	2
3.3.1. Defrost Relay (oA1 = dEF).....	2
3.3.2. Light Relay	2
3.3.3. Auxiliary Relay (oA1 = AUS).....	2
3.3.3.1. Relay Activation by Digital Input (oA1 = AUS, i2F = AUS)	2
3.3.3.2. Auxiliary Thermostat	2
3.3.4. ON/OFF Relay (oA1 = onF).....	2
3.3.5. Neutral Zone Regulation.....	3
3.3.6. Alarm Relay.....	3
3.3.7. Night Blind Management During Energy Saving Cycles.....	3
4 FRONT PANEL COMMANDS	4
4.1. KEYS AND FUNCTIONS	4
4.2. USE OF LEDS	4
5 MAX AND MIN TEMPERATURE MEMORIZATION	5
5.1. HOW TO SEE THE MIN TEMPERATURE	5
5.2. HOW TO SEE THE MAX TEMPERATURE.....	5
5.3. HOW TO RESET MAX AND MIN TEMPERATURE RECORDED	5
6 MAIN FUNCTIONS	6
6.1. HOW TO SEE THE SETPOINT	6
6.2. HOW TO CHANGE THE SETPOINT.....	6
6.3. HOW TO START A MANUAL DEFROST	6
6.4. HOW TO CHANGE A PARAMETER VALUE.....	6
6.5. THE HIDDEN MENU	6
6.5.1. How to Enter the Hidden Menu	6
6.5.2. How to Move a Parameter from the Hidden Menu to the First Level and Vice Versa.....	7
6.6. HOW TO ASSIGN A MODBUS ADDRESS	7
6.7. HOW TO LOCK THE KEYBOARD	7
6.8. TO UNLOCK THE KEYBOARD	7
6.9. THE CONTINUOUS CYCLE.....	7
6.10. THE ON/OFF FUNCTION	7
7 PARAMETERS	8
8 DIGITAL INPUTS	14
8.1. GENERIC ALARM (i2F=EAL)	14
8.2. SERIOUS ALARM MODE (i2F=BAL).....	14

8.3. PRESSURE SWITCH (i2F=PAL)	14
8.4. DOOR SWITCH INPUT (i1F OR i2F=DOR)	14
8.5. START DEFROST (i1F OR i2F=DEF).....	14
8.6. SWITCH THE AUXILIARY RELAY (i2F=AUS)	14
8.7. INVERSION OF THE KIND OF ACTION: HEATING-COOLING (i2F=HTR)	14
8.8. ENERGY SAVING (i2F=ES).....	14
8.9. HOLIDAY DEFROST (i2F=HDF) - ONLY FOR MODELS WITH RTC	14
8.10. ON/OFF FUNCTION (i2F=ONF).....	15
8.11. DIGITAL INPUTS POLARITY.....	15
9 RS485 SERIAL LINE (FOR MONITORING SYSTEMS).....	16
10 X-REP OUTPUT (OPTIONAL).....	16
11 INSTALLATION AND MOUNTING.....	17
12 ELECTRICAL CONNECTIONS.....	17
12.1. PROBE CONNECTION.....	17
13 HOW TO USE THE HOT KEY	18
13.1. HOW TO PROGRAM A HOT KEY FROM THE CONTROLLER (UPLOAD).....	18
13.2. HOW TO PROGRAM THE CONTROLLER USING A HOT KEY (DOWNLOAD)	18
14 ALARM SIGNALS	19
14.1. SILENCING BUZZER / ALARM RELAY OUTPUT.....	19
14.2. ALARM RECOVERY	19
14.3. OTHER MESSAGES	19
15 SPECIFICATIONS.....	20
16 CONNECTIONS	21
17 E2 MODBUS NETWORK WIRING	22
18 ECT MODBUS NETWORKING TO E2S.....	23
18.1. COM PORT ASSOCIATIONS - E2 VERSIONS 3.XX AND BELOW	23
18.2. COM PORT ASSOCIATIONS - E2 VERSIONS 4.2 AND ABOVE	23
18.3. E2 SETUP OF DEVICES	24
18.3.1. <i>Set Up Network Ports</i>	24
18.3.2. <i>Add and Connect the Device</i>	24
18.4. WIRING TYPES.....	26
18.5. MODBUS TERMINATION BLOCKS.....	26
19 DEFAULT SETTING VALUES.....	27
APPENDIX A - ALTERNATE MODBUS COM WIRING METHOD FOR E2, XR, XM, AND XEV DEVICES..	

1 Introduction

1.1. General Warning

Please read the following safety precautions and warnings before using this manual:



CAUTION!

- *This manual is part of the product and should be kept near the controller for easy and quick reference.*
- *The controller should not be used for purposes different from those described in this manual. It cannot be used as a safety device.*
- *Check the application limits before proceeding.*



SAFETY PRECAUTIONS AND WARNINGS!

- *Check that the supply voltage is correct before connecting the controller.*
- *Do not expose to water or moisture: use the controller only within the operating limits and avoid sudden temperature changes with high atmospheric humidity to prevent condensation from forming.*
- *Warning! Disconnect all electrical connections before performing any kind of maintenance.*
- *Fit the probe where it is not accessible by the end user. The controller must not be opened.*
- *In case of failure or faulty operation, send the controller back to the distributor or to Retail Solutions (see address) with a detailed description of the fault.*
- *Verify the maximum current that can be applied to each relay (see Section 15, Specifications).*
- *Ensure that the wires for probes, loads, and the power supply are separated and far enough from each other, without crossing or intertwining.*
- *In case of applications in industrial environments, the use of main filters (our mod. FT1) in parallel with inductive loads could be useful.*

2 Overview

2.1. General Description

Model XR35CX (32 mm x 74 mm) is a digital thermostat with off-cycle defrost, designed for refrigeration applications at normal temperature. It has two (2) relay outputs to control compressor and light (configurable).

It can also have up to four (4) NTC, CtC, or PT1000 probe inputs: the first one for temperature control, the second one located on the evaporator to control the defrost termination temperature. One of the two digital inputs can operate as a third temperature probe. The fourth probe is used to signal the condenser temperature alarm or to display a temperature value. Set the **PbC** parameter to **CtC** to support standard CPC temperature sensors (factory default).

The RS485 serial output enables the controller to be connected to a network line that is a MODBUS-RTU compatible, such as the monitoring units of X-WEB family. The Hot Key receptacle allows the controller to be programmed by means of the Hot Key programming keyboard.

The controller is fully configurable through special parameters that can be easily programmed through the keyboard.

2.2. Ordering Code

Device Name	Dixell Code	Emerson Code
XR35CX - 110VAC	XR35CX -4C6F3B X0LG1MEUB4NA-000	318-6020
XR35CX - 230VAC	XR35CX -5C6F3B X0LG1MEUB5NA-000	318-6021

Table 2-1 - Product Ordering Code

3 Controlling Loads

3.1. Compressor

The regulation is performed according to the temperature measured by the thermostat probe with a positive differential from the setpoint: if the temperature increases and reaches setpoint plus the differential, the compressor is started and then turned OFF when the temperature reaches the setpoint value again.

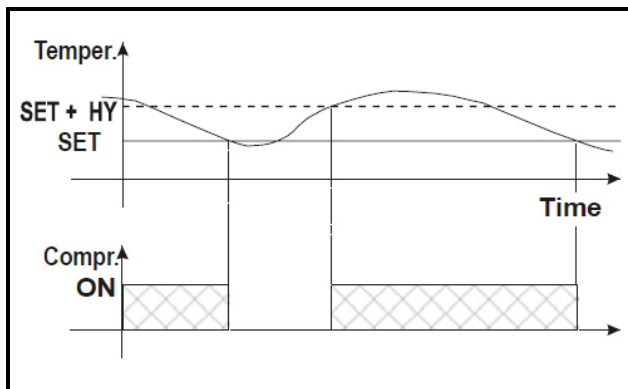

Figure 3-1 - Compressor Temperature Regulation

In case of a fault in the thermostat probe, the start and stop of the compressor are timed through parameters **Con** and **CoF**.

3.2. Defrost

With **oA1** *different from* **dEF** and **tdF = EL**, the controller performs a timed defrost, simply stopping the compressor.

With **oA1 = dEF**, two defrost modes are available through the **tdF** parameter: defrost through electrical heater (**tdF = EL**) and hot gas defrost (**tdF = in**); in this case, the second relay has to be set.

The defrost interval depends on the presence of the RTC (optional). If the RTC is present, it is controlled by means of parameter **EdF**:

- With **EdF = in**, the defrost is made every **IdF** time – standard way for controller without RTC.
- With **EdF = rtC**, the defrost is made in real time depending on the hours set in the parameters **Ld1...Ld6** on workdays and in **Sd1...Sd6** in holidays.

Other parameters are used to control defrost cycles: its maximum defrost duration (**MdF**) and two defrost modes: time or controlled by the evaporator's probe (**P2P**).

3.3. Second Relay Configuration (PAR. oA1; TERM. 1-7)

Depending on the kind of application, the function of the second relay (terminals 1-7) can be set through the **oA1** parameter.

3.3.1. Defrost Relay (oA1 = dEF)

With **oA1 = dEF**, the relay functions as a defrost relay. See Section 3.2., *Defrost* for more details.

3.3.2. Light Relay

With **oA1 = Lig**, the relay operates as light.

3.3.3. Auxiliary Relay (oA1 = AUS)

3.3.3.1. Relay Activation by Digital Input (oA1 = AUS, i2F = AUS)

With **oA1 = AUS** and **i2F = AUS**, the relay 1-7 is switched ON and OFF by a digital input.

3.3.3.2. Auxiliary Thermostat

An anti-condensing heater with the possibility of switching it ON and OFF also by keyboard.

The function of the auxiliary relay can be configured by means of the following parameters:

- **ACH** - Kind of regulation for the auxiliary relay: **Ht**: heating; **CL**: cooling
- **SAA** - Setpoint for auxiliary relay
- **SHy** - Differential for auxiliary relay
- **ArP** - Probe for auxiliary relay
- **Sdd** - Auxiliary output OFF during defrost



NOTE: Set **oA1 = AUS** and **ArP = nP** (no probe for auxiliary output). In this case the relay 1-7 can be activated only by digital input with **i1F** or **i2F = AUS**.

3.3.4. ON/OFF Relay (oA1 = onF)

In this case, the relay is activated when the controller is turned ON and deactivated when the controller is turned OFF.

3.3.5. Neutral Zone Regulation

With **oA1 = db**, relay 1-7 can control a heater element to perform a neutral zone action.

- **oA1** cut in = **SEt - Hy**
- **oA1** cut out = **SEt**

3.3.6. Alarm Relay

With **oA1 = ALr**, the relay 1-7 operates as an alarm relay. It is activated every time an alarm occurs.

Its status depends on the **tbA** parameter: if **tbA = y**, the relay is silenced by pressing any key.

If **tbA = n**, the alarm relay remains ON until the alarm condition recovers.

3.3.7. Night Blind Management During Energy Saving Cycles

With **oA1 = HES**, the relay 1-7 operates to manage the night blind: the relay is energized when the energy saving cycle is activated, by digital input, frontal button or RTC (optional).

4 Front Panel Commands



Figure 4-1 - XR35CX Front Panel

4.1. Keys and Functions

Table 4-1 shows the keys that are found on the front panel of the XR35CX controller and their corresponding functions:

Key	Function
SET	To display the target setpoint; in programming mode, it selects a parameter or confirms an operation.
	(DEF key) To start a manual defrost.
	(UP arrow key) To see the MAX stored temperature; in programming mode, it browses the parameter codes or increases the displayed value.
	(DOWN arrow key) To see the MIN stored temperature; in programming mode, it browses the parameter codes or decreases the displayed value.
	Switches the controller OFF, if onF = oFF .
	Switches the light ON and OFF, if oA1 = Lig .
Key Combinations	

Table 4-1 - XR35CX Front Panel Keys and Functions

	To lock and unlock the keyboard.
SET +	To enter programming mode.
SET +	To return to the room temperature display.

Table 4-1 - XR35CX Front Panel Keys and Functions

4.2. Use of LEDs

Each LED function is described in Table 4-2:

LED	Mode	Function
	ON	Compressor enabled
	Flashing	Anti-short cycle delay enabled
	ON	Defrost enabled
	Flashing	Drip time in progress
	ON	An alarm is occurring
	ON	Continuous cycle is running
	ON	Energy saving enabled
	ON	Light ON
AUX	ON	Auxiliary relay ON
°C/°F	ON	Measurement unit
°C/°F	Flashing	Programming phase

Table 4-2 - LEDs

5 MAX and MIN Temperature Memorization

5.1. How to See the MIN Temperature

1. Press and release the DOWN arrow key.
 2. The **Lo** message will be displayed followed by the minimum temperature recorded.
 3. By pressing the DOWN arrow key again or by waiting 5 seconds, the normal display will be restored.
-

5.2. How to See the MAX Temperature

1. Press and release the UP arrow key.
 2. The **Hi** message will be displayed followed by the maximum temperature recorded.
 3. By pressing the UP arrow key again or by waiting 5 seconds, the normal display will be restored.
-

5.3. How to Reset MAX and MIN Temperature Recorded

1. Press and hold the SET key for more than 3 seconds while the maximum or minimum temperature is displayed. (**rSt** message will be displayed)
2. To confirm the operation, the **rSt** message starts blinking and the normal temperature will be displayed.

6 Main Functions

6.1. How to See the Setpoint



1. Push and immediately release the SET key: the display will show the setpoint value.
2. Push and immediately release the SET key or wait for 5 seconds to display the probe value again.

6.2. How to Change the Setpoint

1. Push the SET key for more than 2 seconds to change the setpoint value.
2. The value of the setpoint will be displayed and the °C or °F LED starts blinking.
3. To change the setpoint value, push the UP or DOWN arrow keys within 10 seconds.
4. To memorize the new setpoint value, push the SET key again or wait 10 seconds.

6.3. How to Start a Manual Defrost



- Push the **DEF** key for more than 2 seconds and a manual defrost will start.

6.4. How to Change a Parameter Value

To change the parameter's value operate as follows:

1. Enter the Programming mode by pressing the SET + DOWN arrow keys for 3 seconds (the °C or °F LED starts blinking).
2. Select the required parameter (refer to **Section 7**,

Parameters for the list of parameters). Press the SET key to display its value.

3. Use the UP or DOWN arrow keys to change its value.
4. Press SET to store the new value and move to the following parameter.
5. To exit, press SET + UP arrow keys or wait 15 seconds without pressing a key.



NOTE: The set value is stored even when the time-out expires and ends the procedure.

6.5. The Hidden Menu

The Hidden Menu includes all the parameters of the controller.

6.5.1. How to Enter the Hidden Menu

1. Enter the Programming mode by pressing the SET + DOWN arrow keys for 3 seconds (the °C or °F LED starts blinking).
2. Immediately release the keys, then push the SET + DOWN arrow keys again for more than 7 seconds. The **Pr2** label will be displayed immediately followed by the **Hy** parameter. *NOW YOU ARE IN THE HIDDEN MENU.*
3. Select the required parameter. See **Section 7, Parameters** for the list of parameters.
4. Press the SET key to display its value.
5. Use the UP or DOWN arrow keys to change its value.
6. Press SET to store the new value and move to the next parameter.
7. Press SET + DOWN arrow keys or wait for 15 seconds without pressing a key to exit.



NOTE: If a parameter is not present in **Pr1**, the **noP** message is displayed after 3 seconds. Keep the keys pressed until the **Pr2** message is displayed.



NOTE: The set value is stored even when the time-out expires and ends the procedure.

6.5.2. How to Move a Parameter from the Hidden Menu to the First Level and Vice Versa

Each parameter present in the Hidden Menu can be removed or put into THE FIRST LEVEL (user level) by pressing SET + DOWN arrow keys.

In the Hidden Menu, when a parameter is present in First Level, the decimal point is visible.

6.6. How to Assign a MODBUS Address

1. Follow *Steps 1 and 2* of Section 6.5.1., *How to Enter the Hidden Menu* to access the Hidden Menu.
2. Select the **Adr** parameter.
3. Press SET to select.
4. Choose the address number using the arrow keys and press SET again to save.
5. Press the SET and UP arrow keys to exit.

Note that devices cannot have duplicate addresses on the network. Assigning MODBUS addresses prior to terminating the network and leaving the address of device 1 as unused until the network is connected can prevent duplicate addressing network issues.

6.7. How to Lock the Keyboard

1. Keep the UP and the DOWN arrow keys pressed for more than 3 seconds.
 2. The **PoF** message will be displayed and the keyboard will be locked. At this point it will be possible to see the setpoint or the MAX or MIN temperature stored only.
 3. If a key is pressed more than 3 seconds, the **PoF** message will be displayed.
-

6.8. To Unlock the Keyboard

To unlock the keyboard, press the UP and the DOWN arrow keys for more than 3 seconds until the **Pon** message displays.

6.9. The Continuous Cycle

When defrost is not in progress, it can be activated by pressing the UP arrow key for about 3 seconds. The compressor operates to maintain the CCS setpoint for the time set through the CCt parameter. The cycle can be terminated before the end of the set time by pressing the same activation key (UP arrow key) for 3 seconds.

6.10. The ON/OFF Function



With **onF = oFF**, pushing the **ON/OFF** key will turn the controller OFF. The **OFF** message is displayed. In this configuration, the regulation is disabled.

To switch the controller ON, push again the **ON/OFF** key.



WARNING! Loads connected to the normally closed contacts of the relays are always supplied and under voltage, even if the controller is in stand-by mode.

7 Parameters

Code	Parameter	Function
REGULATION		
Hy	Differential	(0.1 to 25.5°C / 1 to 255°F) Intervention differential for setpoint. Compressor Cut IN is Setpoint + differential (Hy). Compressor Cut OUT is when the temperature reaches the setpoint.
LS	Minimum setpoint	(-100°C to SEt /-148°F to SEt) Sets the minimum value for the setpoint.
US	Maximum setpoint	(SEt to 110°C/ SEt to 230°F) Sets the maximum value for the setpoint.
ot	Thermostat probe calibration	(-12.0 to 12.0°C; -120 to 120°F) Allows to adjust possible offset of the thermostat probe.
P2P	Evaporator probe presence	n = not present: the defrost stops by time y = present: the defrost stops by temperature
oE	Evaporator probe calibration	(-12.0 to 12.0°C; -120 to 120°F) Allows to adjust possible offset of the evaporator probe.
P3P	Third probe presence (P3)	n = not present: the terminals 18-20 operate as digital input y = present: the terminals 18-20 operate as third probe
o3	Third probe calibration (P3)	(-12.0 to 12.0°C; -120 to 120°F) Allows to adjust possible offset of the third probe.
P4P	Fourth probe presence	(n = not present, y = present)
o4	Fourth probe calibration	(-12.0 to 12.0°C) Allows to adjust possible offset of the fourth probe.
Ods	Outputs activation delay at start up	(0 to 255 min) This function is enabled at the initial start up of the controller and inhibits any output activation for the period of time set in the parameter.
Ac	Anti-short cycle delay	(0 to 50 min) Minimum interval between the compressor stop and the following restart.
rtr	Percentage of the second and first probe for regulation (0 to 100; 100 = P1 , 0 = P2)	Allows to set the regulation according to the percentage of the first and second probe, as for the following formula (rtr(P1 - P2)/100 + P2).
CCt	Compressor ON time during continuous cycle	(0.0 to 24.0 hr, res. 10 min) Allows to set the length of the continuous cycle: compressor stays ON without interruption for the CCt time. Can be used, for instance, when the room is filled with new products.
CCS	Setpoint for continuous cycle	(-100 to 150°C) Sets the setpoint used during the continuous cycle.
Con	Compressor ON time with faulty probe	(0 to 255 min) Time during which the compressor is active in case of faulty thermostat probe. With Con = 0 , compressor is always OFF.

Table 7-1 - List of Parameters

Code	Parameter	Function
CoF	Compressor OFF time with faulty probe	(0 to 255 min) Time during which the compressor is OFF in case of faulty thermostat probe. With CoF = 0 , compressor is always active.
CH	Type of action	CL = cooling; Ht = heating
DISPLAY		
CF	Temperature measurement unit	°C = Celsius; °F = Fahrenheit CAUTION! <i>When the measurement unit is changed, the setpoint and the values of the parameters Hy, LS, US, ot, ALU, and ALL have to be checked and modified if necessary.</i>
rES	Resolution (for °C)	(in = 1°C; dE = 0.1°C) Allows decimal point display.
Lod	Controller display	(P1, P2, P3, P4, SEt, dtr) Selects which probe is displayed by the controller: P1 = Thermostat probe P2 = Evaporator probe P3 = Third probe (only for model with this option enabled) P4 = Fourth probe SEt = setpoint dtr = percentage of visualization
Red	X- REP display (optional)	(P1, P2, P3, P4, SEt, dtr) Selects which probe is displayed by X-REP: P1 = Thermostat probe P2 = Evaporator probe P3 = Third probe (only for model with this option enabled) P4 = Fourth probe SEt = setpoint dtr = percentage of visualization
dLy	Display delay	(0 to 20.0 min, res. 10 sec) When the temperature increases, the display is updated of 1°C/1°F after this time.
dtr	Percentage of the second and first probe for visualization when Lod = dtr (0 to 100; 100 = P1 , 0 = P2)	if Lod = dtr : Allows to set the visualization according to the percentage of the first and second probe, as for the following formula (dtr(P1 - P2)/100 + P2).
DEFROST		
tdF	Defrost type	EL = electric heater; in = hot gas
dFP	Probe selection for defrost termination	nP = no probe P1 = thermostat probe P2 = evaporator probe P3 = configurable probe P4 = probe on Hot Key plug
dtE	Defrost termination temperature	(-50 to 50°C/ -58 to 122°F) (Enabled only when EdF = Pb) Sets the temperature measured by the evaporator probe, which causes the end of defrost.
IdF	Interval between defrost cycles	(0 to 120 hr) Determines the time interval between the beginning of two defrost cycles.

Table 7-1 - List of Parameters

Code	Parameter	Function
MdF	Maximum duration for defrost	(0 to 255 min) When P2P = n , (not evaporator probe: timed defrost), it sets the defrost duration. When P2P = y (defrost end based on temperature), it sets the maximum duration for defrost.
dSd	Start defrost delay	(0 to 99 min) This is useful when different defrost start times are necessary to avoid overloading the plant.
dFd	Temperature displayed during defrost	(rt = real temperature; it = temperature at defrost start; SEt = setpoint; dEF = dEF label)
dAd	MAX display delay after defrost	(0 to 255 min) Sets the maximum time between the end of defrost and the restarting of the real room temperature display.
Fdt	Drip time	(0 to 120 min) Time interval between reaching defrost termination temperature and the restoring of the controller's normal operation. This time allows the evaporator to eliminate water drops that might have formed due to defrost.
dPo	First defrost after start-up	(y = immediate; n = after the IdF time)
dAF	Defrost delay after continuous cycle	(0 to 23.5 hr) Time interval between the end of the fast freezing cycle and the following defrost related to it.
AUXILIARY THERMOSTAT CONFIGURATION (terms. 1-7) - oA1 = AUS		
ACH	Kind of regulation for auxiliary relay	Ht = heating; CL = cooling
SAA	Setpoint for auxiliary relay	(-100 to 110.0°C; -148 to 230°F) Defines the room temperature setpoint to switch auxiliary relay.
SHy	Differential for auxiliary output	(0.1 to 25.5°C / 1 to 255°F) Intervention differential for auxiliary output setpoint. With ACH = CL , AUX Cut in is SAA + SHy ; AUX Cut out is SAA . With ACH = Ht , AUX Cut in is SAA - SHy ; AUX Cut out is SAA .
ArP	Probe selection for auxiliary	nP = no probe, the auxiliary relay is switched only by the digital input P1 = Probe 1 (thermostat probe) P2 = Probe 2 (evaporator probe) P3 = Probe 3 (display probe) P4 = Probe 4
Sdd	Auxiliary relay OFF during defrost	n = the auxiliary relay operates during defrost; y = the auxiliary relay is switched OFF during defrost
ALARMS		
ALP	Probe selection for alarm	nP = no probe, the temperature alarms are disabled P1 = Probe 1 (Thermostat probe) P2 = Probe 2 (evaporator probe) P3 = Probe 3 (display probe) P4 = Fourth probe

Table 7-1 - List of Parameters

Code	Parameter	Function
ALC	Temperature alarms configuration	(Ab ; rE) Ab = Absolute temperature: alarm temperature is given by the ALL or ALU values; rE = Temperature alarms are referred to the setpoint. Temperature alarm is enabled when the temperature exceeds the SEt + ALU or SEt-ALL values.
ALU	MAXIMUM temperature alarm	(ALL to 110°C; ALL to 230°F) When this temperature is reached, the alarm is enabled after the ALd delay time.
ALL	Minimum temperature alarm	(-100°C to ALU ; -148 to ALU) When this temperature is reached, the alarm is enabled after the ALd delay time.
AFH	Differential for temperature alarm recovery	(0.1 to 25.5°C; 1 to 45°F) Intervention differential for recovery of temperature alarm.
ALd	Temperature alarm delay	(0 to 255 min) Time interval between the detection of an alarm condition and alarm signaling.
dAo	Exclusion of temperature alarm at start-up	(from 0.0 min to 23.5 hr) Time interval between the detection of the temperature alarm condition after controller power ON and alarm signaling.
CONDENSER TEMPERATURE ALARM		
AP2	Probe selection for temperature alarm of condenser	nP = no probe P1 = thermostat probe P2 = evaporator probe P3 = configurable probe P4 = probe on Hot Key plug
AL2	Low temperature alarm of condenser	(-100 to 150°C; -148 to 302°F) When this temperature is reached the LA2 alarm is signaled, possibly after the Ad2 delay.
AU2	High temperature alarm of condenser	(-100 to 150°C; -148 to 302°F) When this temperature is reached the HA2 alarm is signaled, possibly after the Ad2 delay.
AH2	Differential for temperature condenser alarm recovery	(0.1 to 25.5°C; 1 to 45°F)
Ad2	Condenser temperature alarm delay	(0 to 255 min) Time interval between the detection of the condenser alarm condition and alarm signaling.
dA2	Condenser temperature alarm exclusion at start up	(from 0.0 min to 23.5 hr, res. 10 min)
bLL	Compressor OFF with low temperature alarm of condenser	n = no: compressor keeps on working Y = yes: compressor is switched OFF until the alarm is present, in any case regulation restarts after Ac time at minimum
AC2	Compressor OFF with high temperature alarm of condenser	n = no: compressor keeps on working Y = yes: compressor is switched OFF till the alarm is present, in any case regulation restarts after Ac time at minimum
AUXILIARY RELAY		

Table 7-1 - List of Parameters

Code	Parameter	Function
tbA	Alarm relay silencing (with oA1 = ALr)	n = silencing disabled: alarm relay stays ON until alarm condition lasts y = silencing enabled: alarm relay is switched OFF by pressing a key during an alarm
oA1	Second relay configuration (1-7)	dEF = defrost; FAn : do not select it!; ALr : alarm; Lig : light; AUS : Auxiliary relay; onF : always ON with controller ON; db = neutral zone; cP2 = do not select it!; dEF2 : do not select it!; HES : night blind
AOP	Alarm relay polarity	Set if the alarm relay is open or closed when an alarm happens. CL = terminals 1-7 closed during an alarm oP = terminals 1-7 open during an alarm
DIGITAL INPUTS		
i1P	Digital input polarity (18-20)	oP = the digital input is activated by opening the contact CL = the digital input is activated by closing the contact
i1F	Digital input configuration (18-20)	dor = door switch function dEF = activation of a defrost cycle
i2P	2 nd digital input polarity (18-19)	oP = the digital input is activated by opening the contact CL = the digital input is activated by closing the contact
i2F	2 nd digital input configuration (18-19)	EAL = external alarm: EA message is displayed; bAL = serious alarm; CA message is displayed; PAL = pressure switch alarm, CA message is displayed; dor = door switch function; dEF = activation of a defrost cycle; ES = energy saving; AUS = auxiliary relay activation with oA1 = AUS ; Htr = kind of action inversion (cooling – heating); FAn = fan; HdF = Holiday defrost (enable only with RTC); onF = to switch the controller OFF
did	With i2F = EAL or i2F = bAL : digital input alarm delay (18-20)	(0 to 255 min) Delay between the detection of the external alarm condition and its signaling.
	With i2F = PAL : time for pressure switch function	(0 to 255 min) Time interval to calculate the number of the pressure switch activation.
doA	Door open signaling delay	(0 to 255 min)
nPS	Pressure switch number	(0 to 15) Number of activation of the pressure switch, during the did interval, before signaling the alarm event (i2F = PAL). If the nPS activation in the did time is reached, switch OFF and ON the controller to restart normal regulation.
Odc	Compressor status when open door	no ; FAn = normal; CPr , F_C = Compressor OFF
rrd	Outputs restart after doA alarm	no = outputs not affected by the doA alarm yES = outputs restart with the doA alarm
HES	Temperature increase during the Energy Saving cycle	(-30.0°C to 30.0°C) Sets the increasing value of the setpoint during the Energy Saving cycle.
TO SET CURRENT TIME AND WEEKLY HOLIDAYS (ONLY FOR MODELS WITH RTC)		
Hur	Current hour (0 to 23 hr)	Sets the current hour.
Min	Current minute (0 to 59 min)	Sets the current minute.
dAY	Current day (Sun to SAT)	Sets the current day of the week.

Table 7-1 - List of Parameters

Code	Parameter	Function
Hd1	First weekly holiday (Sun to <i>not used</i>)	Sets the first day of the week which follows the holiday times. <i>NOTE: Hd1 can be set also as not used value.</i>
Hd2	Second weekly holiday (Sun to <i>not used</i>)	Sets the second day of the week which follows the holiday times. <i>NOTE: Hd2 can be set also as not used value.</i>
TO SET ENERGY SAVING TIMES (ONLY FOR MODELS WITH RTC)		
iLE	Energy Saving cycle start during workdays	(0 to 23 hr 50 min) During the Energy Saving cycle, the setpoint is increased by the value in HES so that the operation setpoint is SEt + HES .
dLE	Energy Saving cycle length during workdays	(0 to 24 hr 00 min) Sets the duration of the Energy Saving cycle on workdays.
iSE	Energy Saving cycle start on holidays. (0 to 23 hr 50 min)	
dSE	Energy Saving cycle length on holidays (0 to 24 hr 00 min)	
TO SET DEFROST TIMES (ONLY FOR MODELS WITH RTC)		
Ld1 to Ld6	Workday defrost start (0 to 23 hr 50 min)	These parameters set the beginning of the 6 programmable defrost cycles during workdays. (e.g., When Ld2 = 12.4 the second defrost starts at 12:40 during workdays.)
Sd1 to Sd6	Holiday defrost start (0 to 23 hr 50 min)	These parameters set the beginning of the 6 programmable defrost cycles on holidays. (e.g., When Sd2 = 3.4 the second defrost starts at 3:40 on holidays.)
<i>NOTE: To disable a defrost cycle, set it to not used. (e.g., If Ld6 = not used, the sixth defrost cycle is disabled.)</i>		
OTHER PARAMETERS		
Adr	Serial address (1 to 244)	Identifies the controller address when connected to a MODBUS compatible monitoring system.
pbC	Type of probe	Allows to set the kind of probe used by the controller: Pt1 = Pt1000 probe ntc = NTC probe CtC = Standard CPC temp sensor Set this pbC parameter to CtC to support standard CPC temp sensors - factory default.
onF	ON/OFF key enabling	not used = disabled oFF = enabled ES = not set it
dP1	Thermostat probe display	
dP2	Evaporator probe display	
dP3	Third probe display (optional)	
dP4	Fourth probe display	
rSE	Real setpoint	Shows the setpoint used during the energy saving cycle or during the continuous cycle.
rEL	Software release	For internal use only.
Ptb	Parameter table code	Read only

Table 7-1 - List of Parameters

8 Digital Inputs

The first digital input 18-20 is enabled with **P3P = n**. With **P3P = n** and **i1F = i2F**, the second digital input is disabled. The free voltage digital inputs are programmable by the **i1F** and **i2F** parameters.

8.1. Generic Alarm (i2F=EAL)

As soon as the digital input is activated, the unit will wait for the **did** time delay before signaling the **EAL** alarm message. The outputs status do not change. The alarm stops just after the digital input is deactivated.

8.2. Serious Alarm Mode (i2F=bAL)

When the digital input is activated, the unit will wait for the **did** delay before signaling the **CA** alarm message. The relay outputs are switched OFF. The alarm will stop as soon as the digital input is deactivated.

8.3. Pressure Switch (i2F=PAL)

If the pressure switch has reached the number of activations (cycles) of the **nPS** parameter during the interval time set by the **did** parameter, the **CA** pressure alarm message will be displayed. The compressor and the regulation are stopped. When the digital input is ON, the compressor is always OFF. *If the **nPS** activation in the **did** time is reached, switch the controller OFF and ON to restart normal regulation.*

8.4. Door Switch Input (i1F or i2F=dor)

This input signals the door status and the corresponding relay output status through the **Odc** parameter: **no**, **Fan** = normal (any change); **CPr**; **F_C** = Compressor OFF.

Since the door is opened, after the delay time set through the parameter **doA**, the door alarm is enabled, the display shows the message **dA** and *the regulation restarts is **rtr = yES***. The alarm stops as soon as the external digital input is disabled again. With the door open, the high and low temperature alarms are disabled.

8.5. Start Defrost (i1F or i2F=dEF)

If conditions are favorable for defrost, a defrost will be started. After the defrost is finished, the normal regulation will restart only if the digital input is disabled, otherwise the controller will wait until the **MdF** safety time is expired.

8.6. Switch the Auxiliary Relay (i2F=AUS)

With **oA1 = AUS**, the digital input switches the status of the auxiliary relay.

8.7. Inversion of the Kind of Action: Heating-Cooling (i2F=Htr)

This function enables the controller to invert the regulation of the controller: from cooling to heating and vice versa.

8.8. Energy Saving (i2F=ES)

The Energy Saving function allows you to change the setpoint value as the result of the **SEt + HES** (parameter) sum. This function is enabled until the digital input is activated.

8.9. Holiday Defrost (i2F=HdF) - Only for Models with RTC

This function enables the holiday defrost setting.

8.10. ON/OFF Function (i2F=onF)

Switches the controller ON and OFF.

8.11. Digital Inputs Polarity

The digital input polarity depends on the **i1P** and **i2P** parameters.

- **i1P** or **i2P** = **CL**: the input is activated by closing the contact.
- **i1P** or **i2P** = **oP**: the input is activated by opening the contact.

9 RS485 Serial Line (for Monitoring Systems)

The RS485 serial line allows you to connect the controller to a monitoring system MODBUS-RTU compatible, such as the X-WEB500/3000/300.

10 X-REP Output (Optional)

Optionally, an X-REP can be connected to the controller through the dedicated connector.

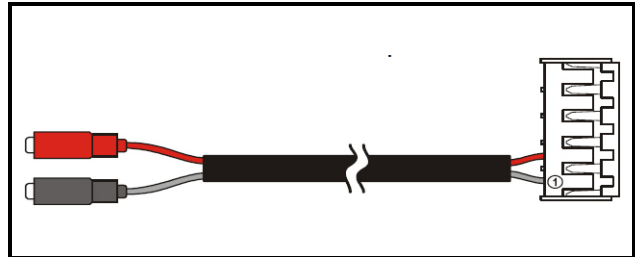

Figure 10-1 - X-REP Output

To connect the X-REP to the controller, the following connectors must be used: CAB-51F(1m), CAB-52F(2m), and CAB-55F(5m).

11 Installation and Mounting

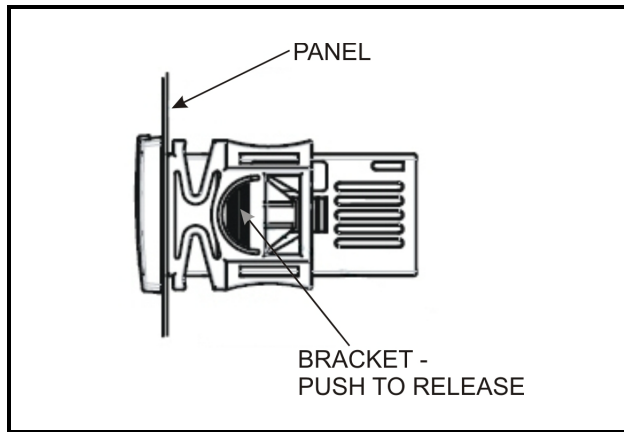

Figure 11-1 - Installation and Mounting of XR35CX

The XR35CX controller should be mounted on a vertical panel, in a 29 x 71 mm hole, and secured using the special bracket supplied.

The temperature range allowed for correct operation is 0 to 60°C. Avoid places subject to strong vibrations, corrosive gases, excessive dirt, or humidity. The same recommendations apply to probes. Allow air to circulate through the cooling holes.

12 Electrical Connections

The controller comes with a screw terminal block to connect cables with a cross section up to 2.5 mm². Before connecting cables, verify that the power supply complies with the controller's requirements. Separate the probe cables from the power supply cables, from the outputs and the power connections. Do not exceed the maximum current allowed on each relay; in case of heavier loads, use a suitable external relay.

12.1. Probe Connection

The probes should be mounted with the bulb upwards to prevent damages due to casual liquid infiltration. It is recommended that the thermostat probe be placed away from air streams to measure the average room temperature correctly. Place the defrost termination probe among the evaporator fans in the coldest place, (where most ice is formed) and far from heaters or from the warmest place during defrost, to prevent premature defrost termination.

13 How to Use the Hot Key



NOTE: The Err message is displayed in case of an error or failure in programming. In this case, turn the unit OFF and then ON if you want to restart the download or remove the Hot Key to abort the operation.

13.1. How to Program a Hot Key From the Controller (Upload)

1. Program one controller using the front keypad.
2. When the controller is ON, insert the Hot Key into the 5-pin receptacle and push the up arrow button; the **uPL** message appears followed by a flashing **End** LED.
3. Push the SET button and the **End** LED will stop flashing to indicate the upload has been successful.
4. Turn OFF the controller, remove the Hot Key, then turn it ON again.



NOTE: The Err message is displayed in case of an error or failure in programming. In this case push the up arrow button again if you want to restart the upload or remove the Hot Key to abort the operation.

13.2. How to Program the Controller Using a Hot Key (Download)

1. Turn OFF the controller by pressing the on/off button  for 5 seconds. **OFF** will display.
2. Insert a programmed Hot Key into the 5-pin receptacle and then turn the Controller ON by pressing the on/off button again for 5 seconds. The normal temperature value will display to indicate the controller is ON.
3. Automatically, the parameter list of the Hot Key is downloaded into the controller memory; the **doL** message will display followed by **End** at the end of the data transfer phase if the controller is programmed correctly.
4. After 10 seconds, the controller will restart working with the new parameters.
5. Remove the Hot Key.

14 Alarm Signals

Message	Cause	Outputs
P1	Room probe failure	Compressor output acc. to par. Con and COF
P2	Evaporator probe failure	Defrost end is timed
P3	Third probe failure	Outputs unchanged
P4	Fourth probe failure	Outputs unchanged
HA	Maximum temperature alarm	Outputs unchanged
LA	Minimum temperature alarm	Outputs unchanged.
HA2	Condenser high temperature	It depends on the Ac2 parameter
LA2	Condenser low temperature	It depends on the bLL parameter
dA	Door open	Compressor restarts
EA	External alarm	Output unchanged
CA	Serious external alarm (iIF = bAL)	All outputs OFF
CA	Pressure switch alarm (iIF = PAL)	All outputs OFF

Table 14-1 - Alarm Signals

Temperature alarms **HA**, **LA**, **HA2**, and **LA2** automatically stop as soon as the temperature returns to normal values.

Alarms **EA** and **CA** (with **iIF = bAL**) recover as soon as the digital input is disabled.

Alarm **CA** (with **iIF = PAL**) recovers only by switching the controller OFF and ON.

14.3. Other Messages

Message	Output
Pon	Keyboard unlocked
PoF	Keyboard locked
noP	In programming mode: No parameter is present in Pr1 .
	On the display or in dp2 , dp3 , dp4 : The selected probe is not enabled.

Table 14-2 - Additional Display Messages

14.1. Silencing Buzzer / Alarm Relay Output

If **tbA = y**, the buzzer and the relay are silenced by pressing any key.

If **tbA = n**, only the buzzer is silenced while the alarm relay is ON until the alarm condition recovers.

14.2. Alarm Recovery

Probe alarms **P1**, **P2**, **P3**, and **P4** start some seconds after the fault in the related probe; they automatically stop some seconds after the probe restarts normal operation. Check connections before replacing the probe.

15 Specifications

Housing	Self extinguishing ABS	
Dimensions	Case: Front: 32 mm x 74 mm, Depth: 60 mm	
	Panel Mount: 71 mm x 29 mm panel cut-out	
Protection	IP 20	
	Frontal: IP65	
Connections	Screw terminal block $\leq 2.5 \text{ mm}^2$ wiring	
Power Supply (depending on the model)	24VAC, $\pm 10\%$ 230VAC, $\pm 10\%$, 50/60Hz 110VAC, $\pm 10\%$, 50/60Hz	
Power Absorption	34VA max	
Display	3 digits, red LED, 14.2 mm high	
Inputs	Up to 4 NTC, CtC, or PT1000 probes	
	Digital: Free voltage contact	
Relay Outputs UL Ratings	Compressor: 120 V, 50/60 Hz, 1/4 HP, 30k cycles 240 V, 50/60 Hz, 1/2 HP, 30k cycles	Terminals 3 and 1
	AUX/Light/Defrost N. O.: 120/240 V, 50/60 Hz, 10A, Resistive, 30k cycles 120/240 V, 50/60 Hz, B300, Pilot Duty, 6k cycles	Terminals 7 and 1
	AUX/Light/Defrost N. C.: 120/240 V, 50/60 Hz, 10A, Resistive, 30k cycles 120/240 V, 50/60 Hz, B300, Pilot Duty, 6k cycles	Terminals 8 and 1
Data Storing	On the non-volatile memory (EEPROM)	
Internal Clock Back-up	24 hours	
Kind of Action	1B	
Pollution Grade	2	
Software Class	A	
Rated Impulsive Voltage	2500V	
Overvoltage Category	II	
Temperature	Operating: 0 to 55°C	
	Storage: -30 to 85°C	
Relative Humidity	20 to 85% (no condensing)	
Measuring and Regulation Range	NTC probe: -40 to 110°C (-40 to 230°F)	
	PT1000 probe: -100 to 150°C (-148 to 302°F)	
Resolution	0.1°C or 1°C or 1 °F (selectable)	
Accuracy (ambient temp. 25°C)	$\pm 0.7^\circ\text{C} \pm 1$ digit	

Table 15-1 - XR35CX Specifications

16 Connections

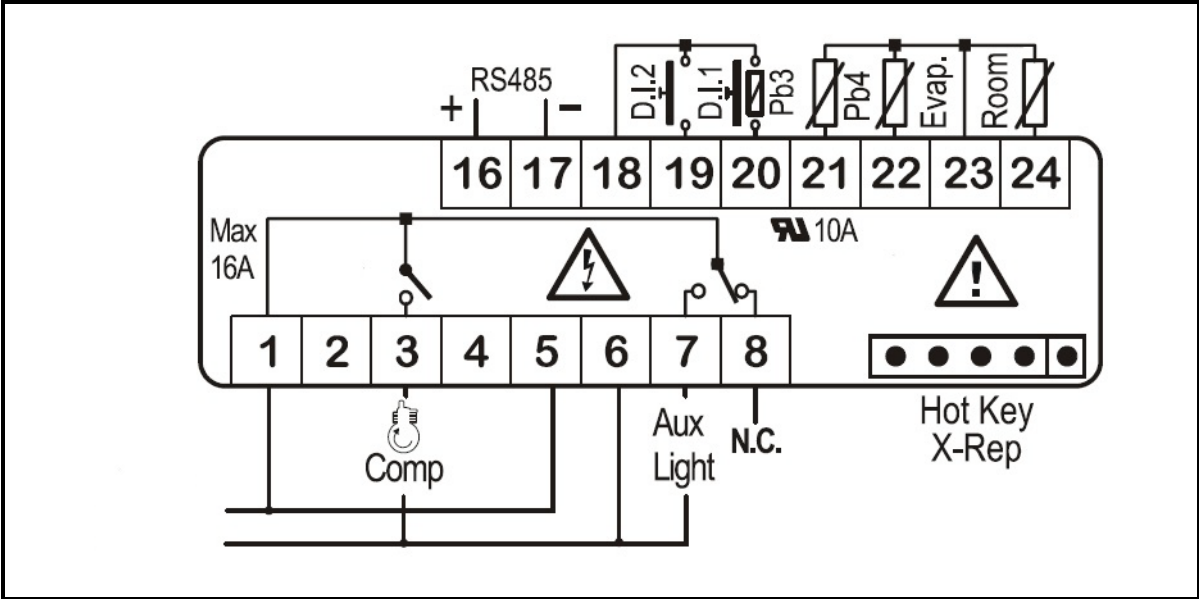

Figure 16-1 - XR35CX Connections

- The X-REP output is optional.

17 E2 MODBUS Network Wiring

- Connect the MODBUS Network to the RS485 Connector on the E2 PIB board (Belden 8641 recommended).
- Note to wire the RS485 +/- polarity at the E2 in the *reverse* of the XR35CX devices.
- Position the three termination jumpers to the UP (terminated) position to provide RS485 termination at the E2.
- Do not connect the shield of the MODBUS network to the E2 PIB center terminal. Instead, use a 100 ohm 1/2 watt resistor to connect the MODBUS cable shield to earth ground.
- At each XR35CX device, wire the MODBUS cable to the RS485 +/- terminals and connect the MODBUS shield to the pin **18** terminal.
- Terminate the end of the MODBUS network at the last XR35CX device on the daisy chain with the MODBUS termination block (P/N 535-2711), or by connecting a 150 ohm resistor between the MODBUS +/- terminals.

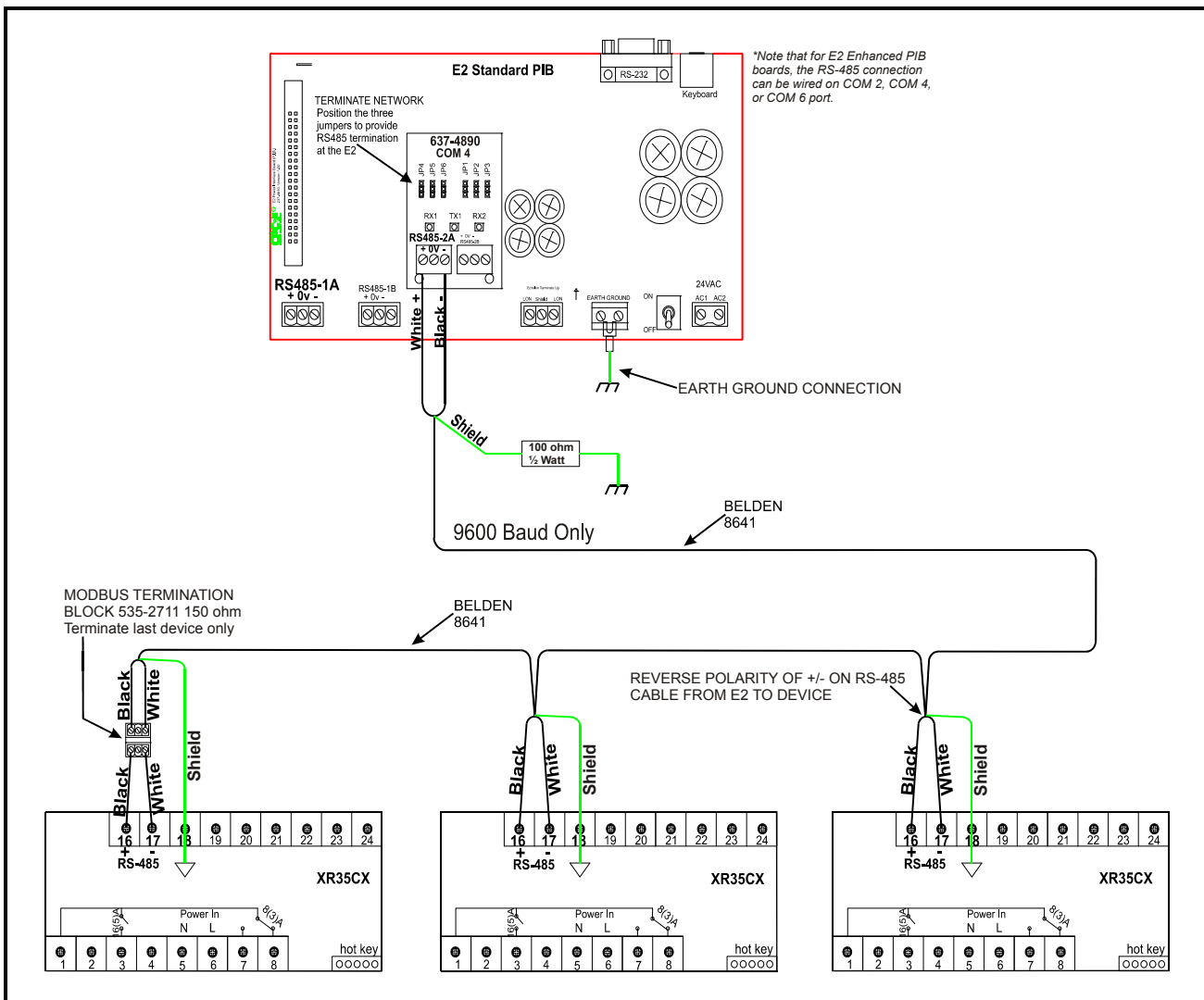

Figure 17-1 - XR35CX to E2 MODBUS Network Wiring

Refer to *Appendix A - Alternate MODBUS COM Wiring Method for E2, XR, XM, and XEV Devices* (Technical Bulletin P/N 026-4148).

18 ECT MODBUS Networking to E2s

18.1. COM Port Associations - E2 Versions 3.xx and Below

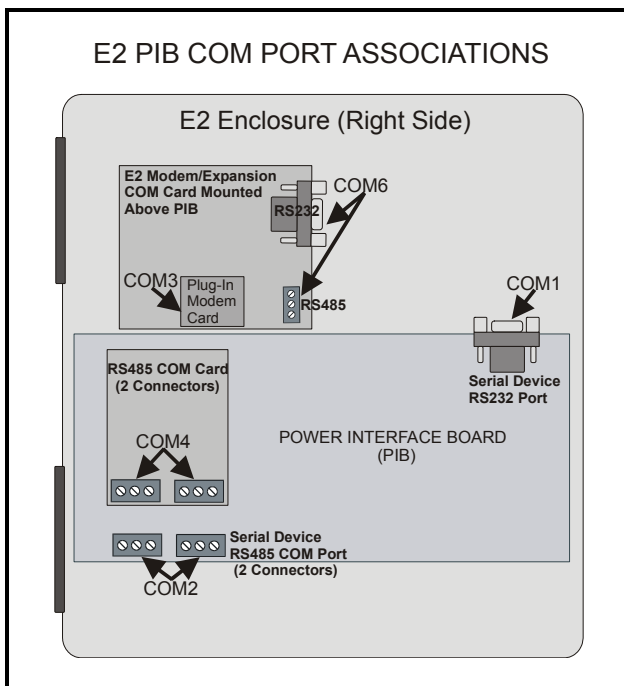

Figure 18-1 - Location of E2 COM Ports (E2 versions 3.xx and below)

Connecting a XR35CX controller to an E2 requires the E2 to be version 2.84 or above. Contact Retail Solutions for upgrade information if the controller is a version before 2.84.

An E2 has up to three COM ports that can be assigned for MODBUS communication: COM2, an RS485 port on the E2 power interface board, and COM4 and COM6, which are optional ports requiring expansion cards. COM4 is recommended for MODBUS connection of XR35CX units.

COM ports can only be used for one function; in other words, if COM2 is set up as the I/O network, you cannot connect MODBUS devices to COM2. Ensure your E2 is equipped with an RS485 COM Card

(P/N 637-4890) and configured in E2 General Services (Menu **7** **3** **1**, **Serial** tab) to enable COM4 or an E2 Expansion COM Card (P/N 637-4871) to enable COM6.

Connect the MODBUS network cable to the three-terminal connector on the COM port you wish to assign as MODBUS. Reverse polarity of +/- on RS485 cable from E2 to the device.

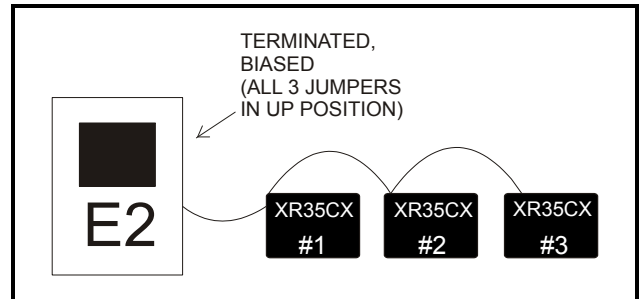

Figure 18-2 - MODBUS Networking

18.2. COM Port Associations - E2 Versions 4.2 and Above

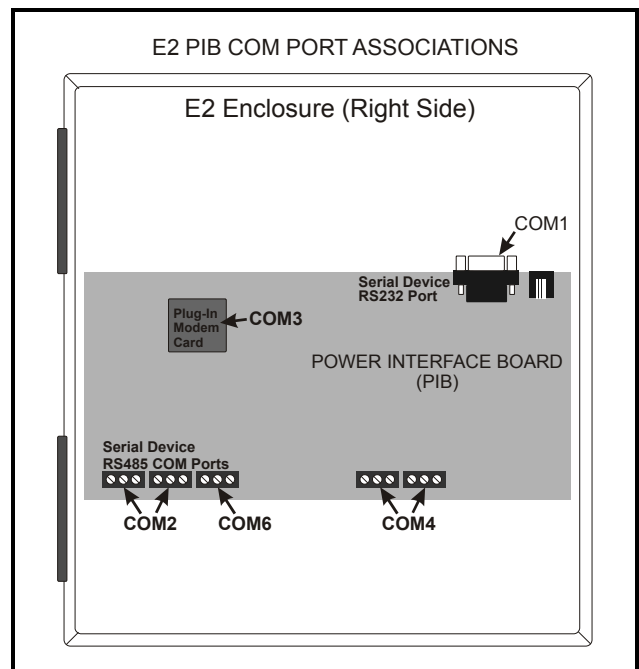

Figure 18-3 - Location of E2 COM Ports - E2 PIB (E2 versions 4.2 and above)

An E2 has three COM ports that can be assigned for MODBUS communication (COM2). COM ports can only be used for one function; in other words, if COM2 is set up as the I/O network, you cannot connect MODBUS devices to COM2. Ensure your E2 is configured in E2 General Services (Menu 7 3 1, Serial tab) to enable COM4 or COM6.

18.3. E2 Setup of Devices

18.3.1. Set Up Network Ports

Before setting up a device, the port on the E2 that has the MODBUS cable connected must be set up as a MODBUS port.

1. Log in to the E2 with Level 4 access.
2. Press Menu followed by 7 3 1 - General Controller Info.
3. Press Ctrl + 3 to open the Serial tab of the General Controller Info setup screens:

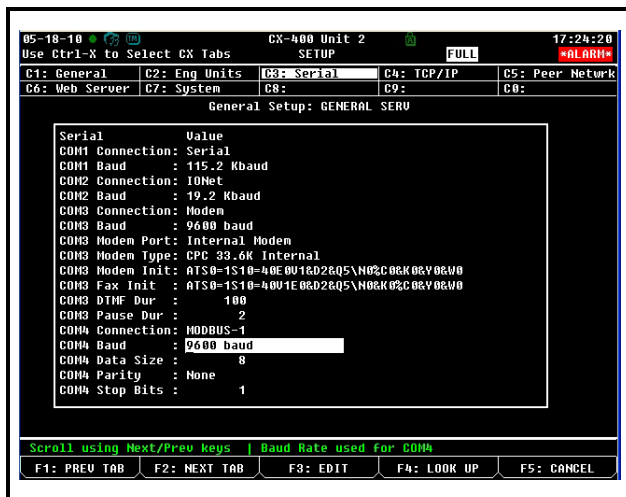

Figure 18-4 - Serial Communications Manager Screen

4. This screen will have a "Connection" field for all COM ports on the E2. Highlight the COM port connection field that will be used for the device, and press F4 - LOOK UP. From the list of network types, select MODBUS.
5. Four fields will become visible underneath the COM port connection field, which pertain to the way the device communicates:
 - **Baud** - Default setting is 19.2k. The baud rate setting should be set to match the baud rate of the device (9600). (All devices connected to the same

COM port should be set to the same baud rate.)

- **Data Size** - Leave this field at the default value (8).
 - **Parity** - Leave this field at the default value (None).
 - **Stop Bits** - Leave this field at the default value (1).
6. Press the arrow key to save changes and exit.

18.3.2. Add and Connect the Device

To enable communications between E2 and the XR35CX units, the devices must be added and addressed in E2.

1. Log in to the E2 with Level 4 access.
2. Press Menu 7 7 2 - Connected I/O Boards and Controllers.

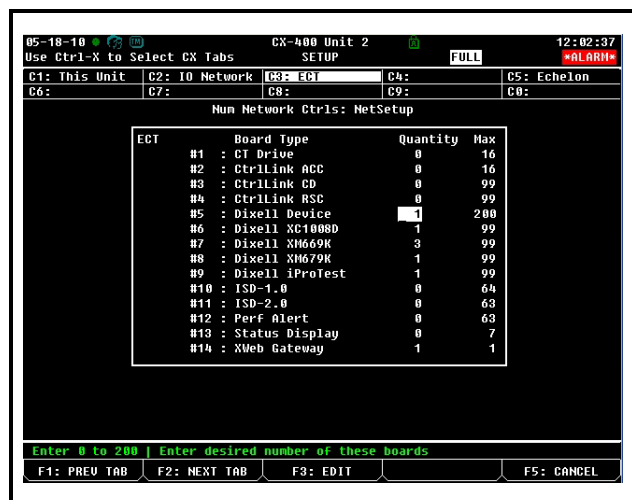

Figure 18-5 - Num Network Ctrls: NetSetup Screen

3. In the Num Network Ctrls: NetSetup screen, under the ECT tab, enter the number of devices in the Quantity field. (Max shows the maximum number of devices allowed on the network.)
4. Press the arrow key to return to the Network Setup menu, then select 1 - Network Summary.
5. Locate the units you added to the network list (press Page Up and Page Down to scroll through the list). If desired, en-

ter a new name for each device in the **Name** field.

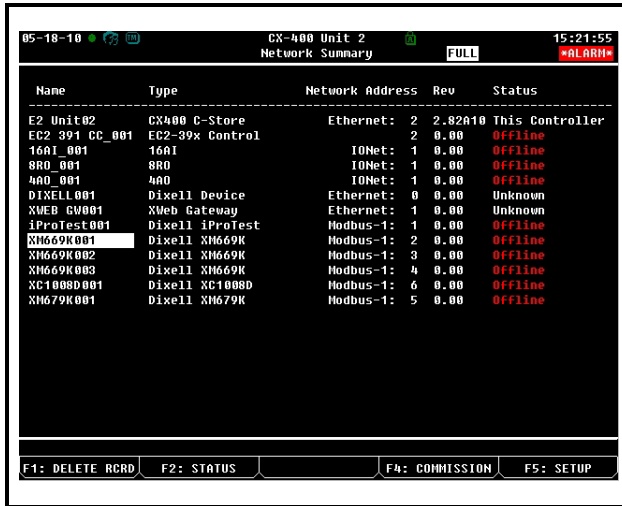

Figure 18-6 - Network Summary Screen

- By default, each device in the network list has a board number of 0. To set the address and begin communication, choose the device and press **F4**. In the list of MODBUS devices, choose the address number corresponding to the XR35CX address set up through the XR35CX front display, and press **Enter** to select it. A window will open where you can specify the address of the controller. If a network ID has already been selected, its name will be shown next to the network ID in this list. If the network ID you are trying to assign has already been used, you must set the address on this device to a different number that is not being used.

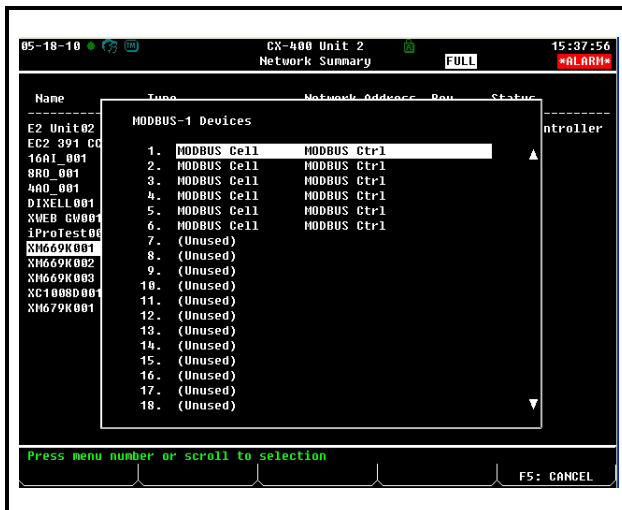

Figure 18-7 - List of MODBUS Devices

- Repeat **Steps 5** and **6** until each device has a name and address.

- When finished, press **Esc** to return to the *Network Setup* menu, then press **F1** - **Network Summary** (Figure 18-8). Locate the devices you set up, and look at each device's status in the **Status** field. You will see one of the following messages:

- Online** - The device is communicating normally.
- Offline** - The device is not communicating, has not been commissioned, is not functional, or is not powered up. Verify the device is powered up, wired correctly, and has the proper network address, baud rate, and parity.
- Unknown** - The device is not communicating or has not been commissioned. Verify the device is powered up, wired correctly, and has the proper network address, baud rate, and parity.
- No Port** - No port is set up in the E2 Serial Configuration Manager to be a MODBUS port.
- Wrong FW Rev** - This message is likely caused by the device having a firmware version older than the minimum revision required by E2 for communication. Replace the device with a new one or a device that has the latest version of firmware on it.

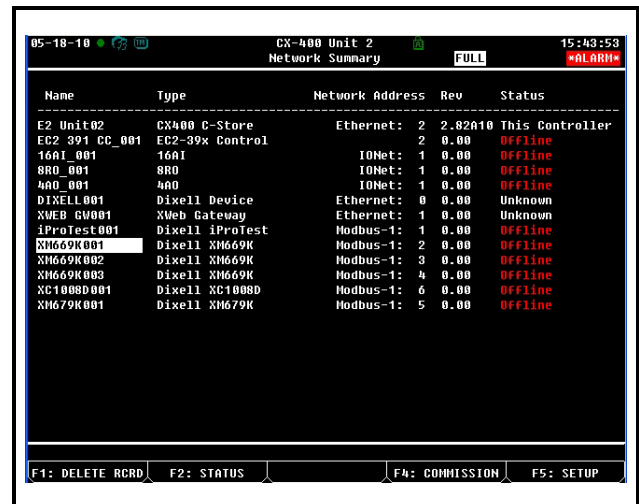

Figure 18-8 - Network Summary Screen

18.4. Wiring Types

Retail Solutions specifies Belden #8761 shielded twisted pair cables for use as MODBUS wiring (or Belden #82761 and Belden #88761 for plenum installations).

For MODBUS network wiring of XR35CX controllers to E2, Belden #8641 (*Retail Solutions P/N 135-8641*) is the recommended wire type to use.

If the recommended cable is not available in your area, be sure the wiring meets or exceeds the following specs:

Shielded?	Yes
Conductor Type	Twisted Pair
Gauge	18 - 24 AWG
Capacitance between signal wires	31 pF/ft or less (9.45 m) or less
Capacitance between signal and shield	59 pF/ft or less (17.98 m) or less
Maximum Length	4000 ft/18 to 22 AWG (1219.2 m) 2500 ft/24 AWG (762 m)
Nominal Impedance	120Ω±50Ω

18.5. MODBUS Termination Blocks

Because the XR35CX device has no on-board means of termination, use the MODBUS termination block (*P/N 535-2711*) for termination that can be wired to the end of the cable segment using the three-pin connector. Wire the two signal wires to the outside terminals, and connect the shield to pin 18, keeping the exposed shield wire length as short as possible (3 inches ideal maximum length).

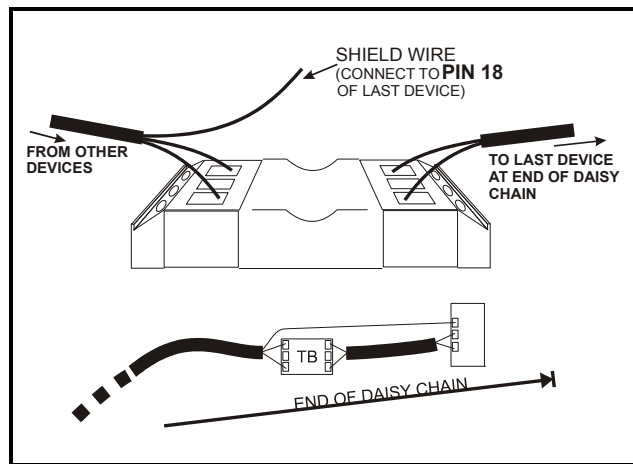

Figure 18-9 - MODBUS Termination Block (*P/N 535-2711*)

19 Default Setting Values

Label	Name	Range	Value	Level
SEt	Setpoint	LS to US	3.0	---
Hy	Differential	0.1 to 25.5°C/ 1 to 255°F	2.0	Pr1
LS	Minimum setpoint	-100°C to SEt /-58°F to SEt	-50.0	Pr2
US	Maximum setpoint	SEt to 110°C/ SEt to 230°F	110	Pr2
ot	Thermostat probe calibration	-12 to 12°C /-120 to 120°F	0.0	Pr1
P2P	Evaporator probe presence	n = not present; Y = present	Y	Pr1
oE	Evaporator probe calibration	-12 to 12°C /-120 to 120°F	0.0	Pr2
P3P	Third probe presence	n = not present; Y = present	n	Pr2
o3	Third probe calibration	-12 to 12°C /-120 to 120°F	0	Pr2
P4P	Fourth probe presence	n = not present; Y = present	n	Pr2
o4	Fourth probe calibration	-12 to 12°C /-120 to 120°F	0	Pr2
Ods	Outputs delay at start up	0 to 255 min	0	Pr2
Ac	Anti-short cycle delay	0 to 50 min	1	Pr1
rtr	P1-P2 percentage for regulation	0 to 100 (100 = P1 , 0 = P2)	100	Pr2
CCt	Continuous cycle duration	0.0 to 24.0 hr	0.0	Pr2
CCS	Setpoint for continuous cycle	(-100 to 150.0°C) (-67 to 302°F)	3	Pr2
Con	Compressor ON time with faulty probe	0 to 255 min	15	Pr2
CoF	Compressor OFF time with faulty probe	0 to 255 min	30	Pr2
CH	Kind of action	CL ; Ht	CL	Pr1
CF	Temperature measurement unit	°C to °F	°C	Pr2
rES	Resolution	in = integer; dE = decimal point	dE	Pr1
Lod	Probe displayed	P1 ; P2	P1	Pr2
Red²	X-REP display	P1 – P2 – P3 – P4 – SEt – dtr	P1	Pr2
dLy	Display temperature delay	0 to 20.0 min (10 sec)	0.0	Pr2
dtr	P1-P2 percentage for display	1 to 99	50	Pr2
EdF*	Kind of interval for defrost	rtC to in	rtC	Pr2
tdF	Defrost type	EL = electrical heater; in = hot gas	EL	Pr2
dFP	Probe selection for defrost termination	nP ; P1 ; P2 ; P3 ; P4	P2	Pr2
dtE	Defrost termination temperature	-50 to 50°C	8.0	Pr1
IdF	Interval between defrost cycles	1 to 120 hr	8	Pr1
MdF	Maximum duration for defrost	0 to 255 min	20	Pr1
dSd	Start defrost delay	0 to 99 min	0	Pr2
dFd	Displaying during defrost	rt , it , SEt , dEF	it	Pr2
dAd	MAX display delay after defrost	0 to 255 min	30	Pr2

Table 19-1 - Default Setting Values (² Only for XR35CX with X-REP output)

Label	Name	Range	Value	Level
Fdt	Draining time	0 to 120 min	0	Pr2
dPo	First defrost after start-up	n = after IdF ; y = immediate	n	Pr2
dAF	Defrost delay after fast freezing	0 to 23 hr and 50'	0.0	Pr2
ACH	Kind of action for auxiliary relay	CL ; Ht	CL	Pr2
SAA	Setpoint for auxiliary relay	-100 to 110°C / -58 to 230°F	0.0	Pr2
SHy	Differential for auxiliary relay	0.1 to 25.5°C / 1 to 255°F	2.0	Pr2
ArP	Probe selection for auxiliary relay	nP/P1/P2/P3/P4	nP	Pr2
Sdd	Auxiliary relay operating during defrost	n to y	n	Pr2
ALP	Alarm probe selection	nP ; P1 ; P2 ; P3 ; P4	P1	Pr2
ALC	Temperature alarms configuration	rE = related to set; Ab = absolute	Ab	Pr2
ALU	MAXIMUM temperature alarm	SEt to 110.0°C; SEt to 230°F	110.0	Pr1
ALL	Minimum temperature alarm	-100°C to SEt / -58°F to SEt	-50.0	Pr1
AFH	Differential for temperature alarm recovery	(0.1°C to 25.5°C) (1°F to 45°F)	2.0	Pr2
ALd	Temperature alarm delay	0 to 255 min	15	Pr2
dAo	Delay of temperature alarm at start up	0 to 23 hr and 50'	1.3	Pr2
AP2	Probe for temperature alarm of condenser	nP ; P1 ; P2 ; P3 ; P4	P4	Pr2
AL2	Condenser for low temperature alarm	(-100 to 150°C) (-67 to 302°F)	-40	Pr2
AU2	Condenser for high temperature alarm	(-100 to 50°C) (-67 to 302°F)	110	Pr2
AH2	Differ. for condenser temperature alarm recovery	(0.1°C to 25.5°C) (1° to 45°F)	5	Pr2
Ad2	Condenser temperature alarm delay	0 to 254 (min), 255 = not used	15	Pr2
dA2	Delay of condenser temperature alarm at start up	0.0 to 23 hr 50'	1.3	Pr2
bLL	Compressor OFF for condenser low temperature alarm	n(0) - Y(1)	n	Pr2
AC2	Compressor OFF for condenser high temperature alarm	n(0) - Y(1)	n	Pr2
tbA	Alarm relay disabling	n = no y = yes	y	Pr2
oA1	Second relay configuration	ALr = alarm, dEF = defrost, Lig = Light, AUS = AUX, onF = always ON, Fan = do not select it, db = neutral zone, cp2 = second compressor, df2 = do not select it, HES = night blind	Lig	Pr2
AOP	Alarm relay polarity (oA1 = ALr)	oP ; CL	CL	Pr2
i1P	Digital input polarity (18-20)	oP = opening, CL = closing	CL	Pr1
i1F	Digital input 1 configuration (18-20)	dor ; dEF	dor	Pr1
i2P	Digital input polarity (18-19)	oP = opening, CL = closing	CL	Pr1
i2F	Digital input configuration (18-19)	EAL - bAL - PAL - dor - dEF - ES - AUS - Htr - FAn - HdF - onF	EAL	Pr2

Table 19-1 - Default Setting Values (² Only for XR35CX with X-REP output)

Label	Name	Range	Value	Level
did	Digital input alarm delay (18-20)	0 to 255 min	15	Pr2
doA	Door open alarm delay	0 to 255 min	15	Pr1
nPS	Number of activation of pressure switch	0 to 15	15	Pr2
Odc	Compress status when open door	no; Fan; CPr; F_C	F-C	Pr2
rrd	Regulation restart with door open alarm	n – Y	y	Pr2
HES	Differential for Energy Saving	(-30°C to 30°C) (-54°F to 54°F)	0	Pr2
Hur*	Current hour	0 to 23	---	Pr1
Min*	Current minute	0 to 59	---	Pr1
dAY*	Current day	Sun to SA _t	---	Pr1
Hd1*	First weekly holiday	Sun to SA _t – not used	not used	Pr1
Hd2*	Second weekly holiday	Sun to SA _t – not used	not used	Pr1
iLE*	Energy Saving cycle start during work-days	0 to 23 hr 50 min	0.0	Pr1
dLE*	Energy Saving cycle length during work-days	0 to 24 hr 00 min	0	Pr1
iSE*	Energy Saving cycle start on holidays	0 to 23 hr 50 min	0.0	Pr1
dSE*	Energy Saving cycle length on holidays	0 to 24 hr 00 min	0	Pr1
Ld1*	1 st workdays defrost start	0 to 23 hr 50 min - not used	6.0	Pr1
Ld2*	2 nd workdays defrost start	0 to 23 hr 50 min - not used	13.0	Pr1
Ld3*	3 rd workdays defrost start	0 to 23 hr 50 min - not used	21.0	Pr1
Ld4*	4 th workdays defrost start	0 to 23 hr 50 min - not used	not used	Pr1
Ld5*	5 th workdays defrost start	0 to 23 hr 50 min - not used	not used	Pr1
Ld6*	6 th workdays defrost start	0 to 23 hr 50 min - not used	not used	Pr1
Sd1*	1 st holiday defrost start	0 to 23 hr 50 min - not used	6.0	Pr1
Sd2*	2 nd holiday defrost start	0 to 23 hr 50 min - not used	13.0	Pr1
Sd3*	3 rd holiday defrost start	0 to 23 hr 50 min - not used	21.0	Pr1
Sd4*	4 th holiday defrost start	0 to 23 hr 50 min - not used	not used	Pr1
Sd5*	5 th holiday defrost start	0 to 23 hr 50 min - not used	not used	Pr1
Sd6*	6 th holiday defrost start	0 to 23 hr 50 min - not used	not used	Pr1
Adr	Serial address	1 to 247	1	Pr2
pbC	Kind of probe	Pt1000, ntc, CtC. Set this PbC parameter to CtC to support standard CPC temp sensors - factory default.	ntc	Pr2
onF	ON/OFF key enabling	not used, oFF, ES	not used	Pr2
dP1	Room probe display	---	---	Pr1
dP2	Evaporator probe display	---	---	Pr1
dP3	Third probe display	---	---	Pr1

Table 19-1 - Default Setting Values (² Only for XR35CX with X-REP output)

Label	Name	Range	Value	Level
dP4	Fourth probe display	---	---	Pr1
rSE	Real set	actual set	---	Pr2
rEL	Software release	---	2.6	Pr2
Ptb	Map code	---	---	Pr2

Table 19-1 - Default Setting Values (² Only for XR35CX with X-REP output)

Appendix A - Alternate MODBUS COM Wiring Method for E2, XR, XM, and XEV Devices

Overview

To simplify MODBUS communication wiring with E2, (both Standard and Enhanced versions) XR, XM, and XEV series devices, the alternate method outlined below may be used.

Wire Type

Use Belden 8761 or equivalent cable.

Shield

DO NOT connect the shield to the device. Keep the shield continuous throughout a network segment. The shield must be twisted together and insulated with electrical tape or heatshrink at each device within a network segment. Securely connect the shield to an earth grounded chassis at each end of a network segment.

Termination

Each network segment must be biased and terminated at the E2 controller's end (all three jumpers in the MOD position for E2 Enhanced, or all three jumpers in the UP position for E2 Standard) and terminated with a 150 ohm resistor at the other end of the network segment (150 ohms between the two communication wires).

Recommended

For reliable communication on some installations, it may be necessary to connect a 100 ohm resistor between the XR, XM, or XEV device's previously identified ground terminal and earth ground.

Some E2 MODBUS COM Ports Can Support Two Network Segments

For E2 Enhanced 4.x Controller Hardware

COM2 supports two network segments: one on connector RS485-COM2A, and the second on connector RS485-COM2B.

COM4 supports two network segments: one on connector RS485-COM4A, and the second on connector RS485-COM4B.

COM6 only supports one network segment on connector RS485-COM6.

For E2 Standard 3.x Controller Hardware

COM2 supports two network segments: one on connector RS485-1A, and the second on connector RS485-1B.

For information on the maximum recommended number of XR, XM, and XEV devices for each network segment (load and bandwidth calculations), contact Emerson Retail Solutions Technical Support at 770-425-2724.

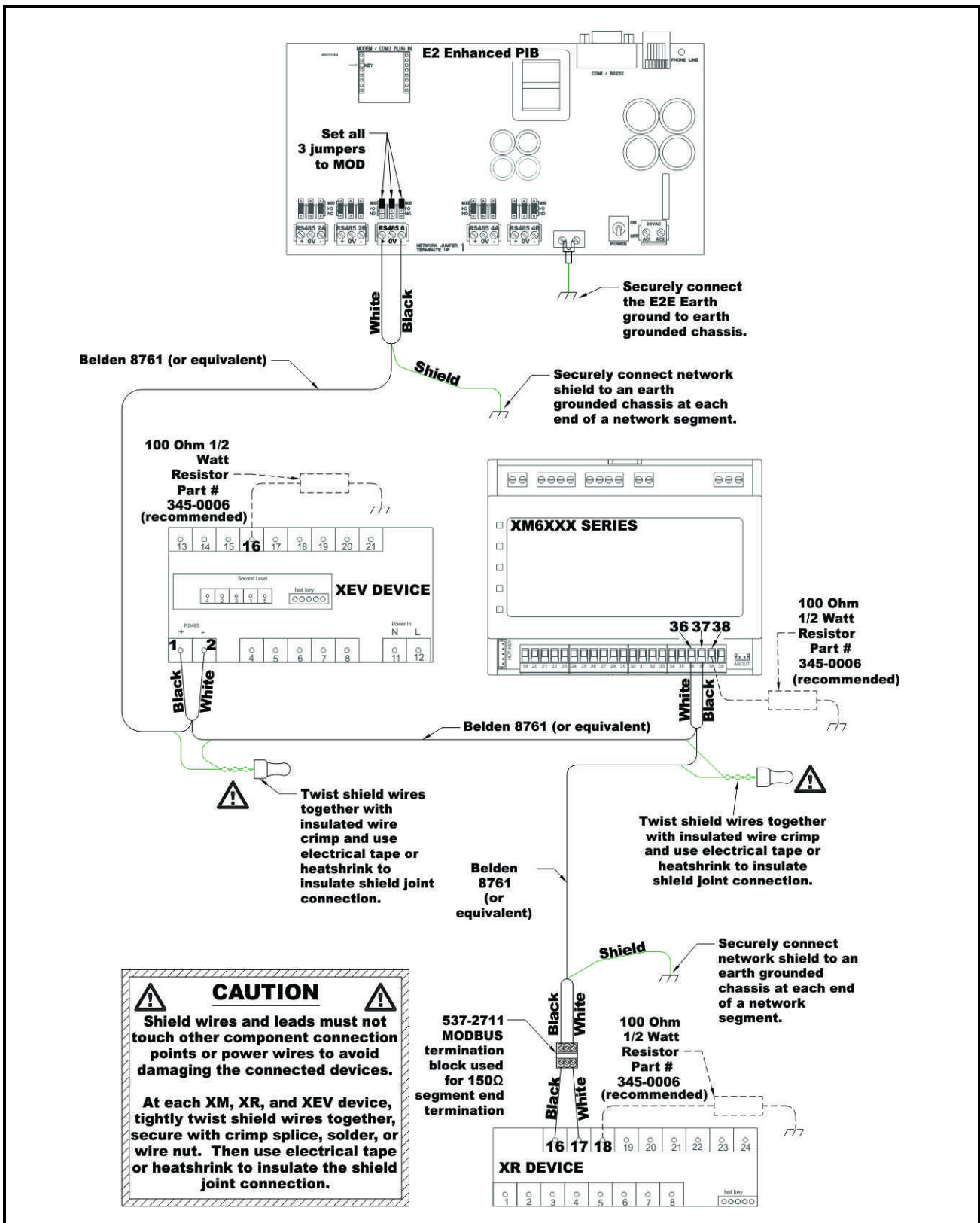

Figure A -I - MODBUS Com Wiring Diagram

The contents of this publication are presented for informational purposes only and they are not to be construed as warranties or guarantees, express or implied, regarding the products or services described herein or their use or applicability. Emerson Climate Technologies Retail Solutions, Inc. and/or its affiliates (collectively "Emerson"), reserves the right to modify the designs or specifications of such products at any time without notice. Emerson does not assume responsibility for the selection, use or maintenance of any product. Responsibility for proper selection, use and maintenance of any product remains solely with the purchaser and end-user.

026-1203 03-FEB-2015 Emerson is a trademark of Emerson Electric Co. ©2015 Emerson Climate Technologies Retail Solutions, Inc. All rights reserved.