

Condensing Unit Technical Data Sheet

Model CGU45TG_N
Voltage 200-230/220-240V 50/60Hz ~1
Refrigerant R134a

APPLICATION

Application High-Medium Back Pressure
 Refrigerant R134a
 Evaporating Temp. -25,0 °C to 10,0 °C
 Expansion Capillar/Valve
 Comp. Cooling Fan cooled
 Max. ambient temp. 43,0 °C

COMPRESSOR

Displacement 4,50 cm³
 Diameter 22,00 mm
 Stroke 11,88 mm
 Oil type ISO VG 22 ESTER
 Oil charge 220 cm³

MOTOR

Nominal Power 1/6 hp
 Voltage/Frequency 200-230V 50Hz
 Voltage range 170-253 V
 Type CSIR
 Phase number 1 PH
 Locked Rotor Amps (LRA) 8,90 A
 Max. Cont. Current (MCC) 0,00 A
 Main W. resist. at 25°C 17,00 Ω
 Start W. resist. at 25°C 40,30 Ω

NOMINAL PERFORMANCE

Cooling Capacity	470 W
COP	2,34 W/W
EER	2,01 kCal/Wh
Input Power	201 W
Current	1,29 A

ASHRAE

TEST CYCLE CONDITIONS

	HMBP
Evaporating temp. (T _e)	7,2 °C
Condensing temp. (T _c)	55,0 °C
Liquid temp. (T _{liq.})	46,0 °C
Ambient temp. (T _{amb.})	35,0 °C
Suction temp. (T _{suction})	35,0 °C
Voltage/Frequency	200 V 50 Hz

CONDENSER AND FAN DATA

Condenser type	CU-AL
Condenser model	7T 2R
Fan blade (Ø mm / °)	172 / 28
Fan motor	5W 200V 50/60Hz

WIRING DIAGRAM

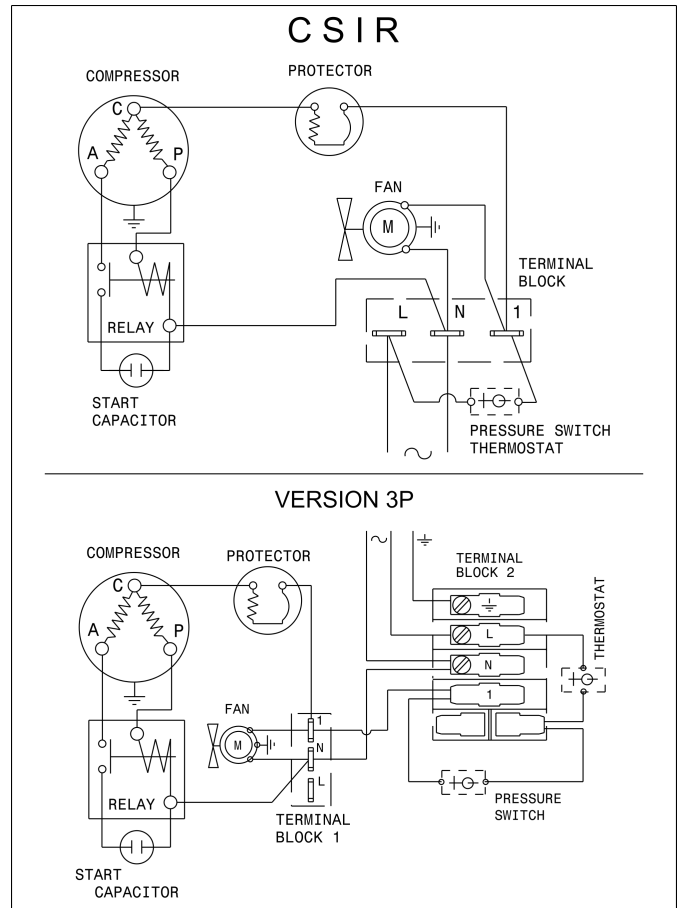

REFRIGERATION CAPACITY (W) Evaporating Temperature (°C)

Model	Motor	-25	-15	-5	5	7.2			10
						W	Winp	A	
CGU45TG_N	CSIR	101	177	287	433	470	201	1.29	519

ASHRAE HMBP: Condensing temperature: 55°C, Liquid temperature: 46°C, Suction temperature: 35°C, Ambient temperature: 35°C

Condensing Unit Technical Data Sheet

VERSIONS

VERSION 1	VERSION 2	VERSION 3	VERSION 3P	VERSION 4
Tube	Service valve	Service valve and receiver	Service valve, receiver, pressure switch	Schrader valve on the service port
Suction tube internal diam.: 6,1 mm Discharge tube internal diam.: 4,9 mm Net Weight: 13,4 Kg	Suction valve: 3/8" Discharge valve: 1/4" Net Weight: 13,9 Kg	Receiver vol.: 0,9 l Suction valve: 3/8" Discharge valve: 1/4" Net Weight: 16,7 Kg	Receiver vol.: 0,9 l Suction valve: 3/8" Discharge valve: 1/4" Net Weight: 17,8 Kg	Suction tube internal diam.: 6,1 mm Discharge tube internal diam.: 4,9 mm Net Weight: 14,4 Kg

DIMENSIONS (Version 3 drawing)

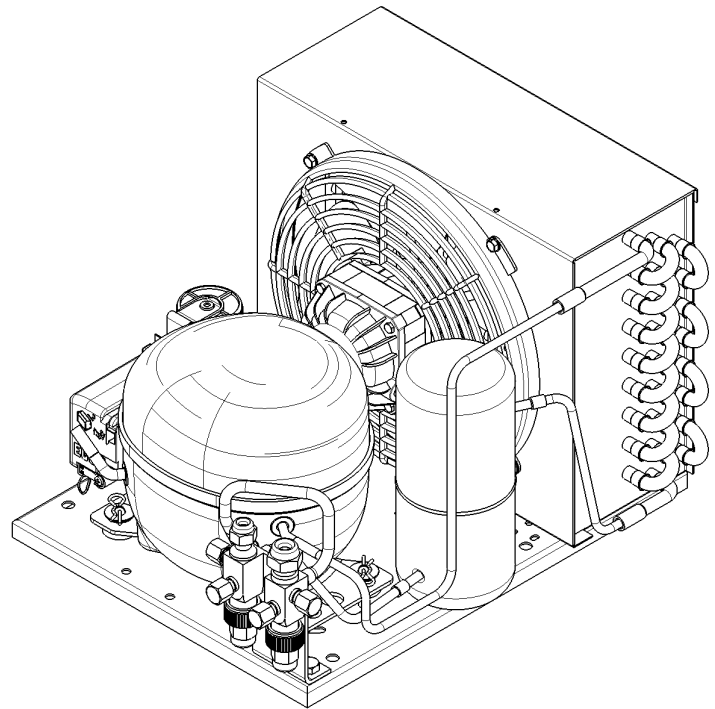
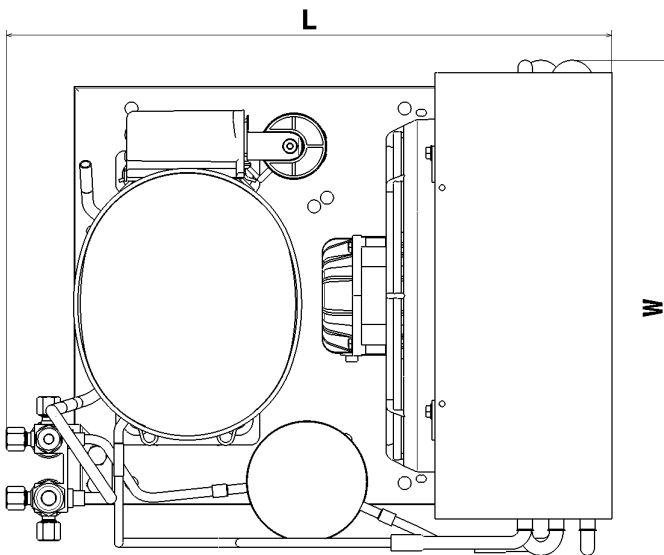
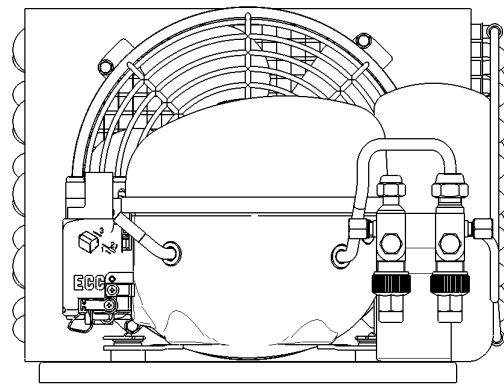
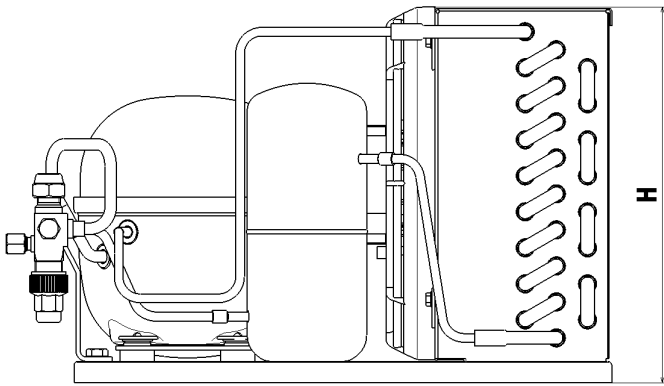

VERSION 1-4 (WxLxH) (mm)	VERSION 2 (WxLxH) (mm)	VERSION 3 (WxLxH) (mm)	VERSION 3P (WxLxH) (mm)
305x390x203	315x425x203	320x425x208	335x430x240