

MODEL NUMBER
⑧ ZP61KCE-TF7
④ ZP72KCE-TFD, TF7, TF5
⑤ ZP83KCE-TF7
⑨ ZP54K3E-TF7

SPECIFICATIONS	
ES NO.	DESCRIPTION
ES92-155	CONVERSION-METRIC

NOTES:  
 ① ALL TOLERANCES ±1.50 [0.060] UNLESS OTHERWISE SPECIFIED.  
 DUE TO ACCUMULATED ASSEMBLY TOLERANCES THE LISTED COMPONENTS MAY VARY FROM THE MOUNTING HOLES AS SHOWN BELOW:

② ALL FITTINGS : ±3.0 [0.12]  
 ② MOUNTING KIT  
 ③ TUBE ENDS MUST BE PLUGGED.

GROMMET DUROMETER	4 FOOT KIT
35-45	527-0205-00

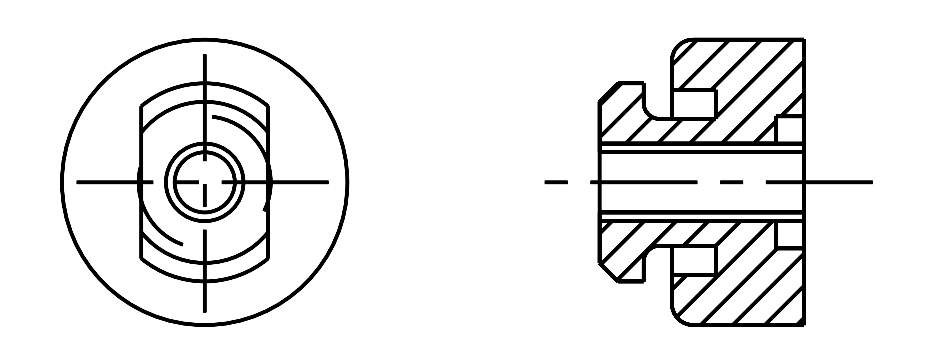

Ø17.45 PIN CIRCLE [0.687] MODELS: TFD, TFE, TFM, TF7  
 Ø13.46 PIN CIRCLE [0.530] MODELS: PFV, PFJ, TFW, TF5

⑨ USE COPPER CONDUCTORS ONLY. USE MINIMUM 75° C WIRE FOR AMPACITY DETERMINATION. INTERNAL MOTOR PROTECTION - ALLOW TIME FOR RESET. OVERCURRENT PROTECTION DEVICE RATING AND TYPE MUST BE IN ACCORDANCE WITH REGULATORY AGENCY END PRODUCT APPROVALS - SEE SYSTEM NAMEPLATE. CRANKCASE HEATER, WHEN APPLIED, MUST BE CONNECTED ONLY TO ITS RATED VOLTAGE. TO CORRECT IMPROPER ROTATION OF THREE PHASE MODELS, SWITCH ANY TWO SUPPLY LINES. REFER TO THE APPLICABLE SYSTEM WIRING DIAGRAM.

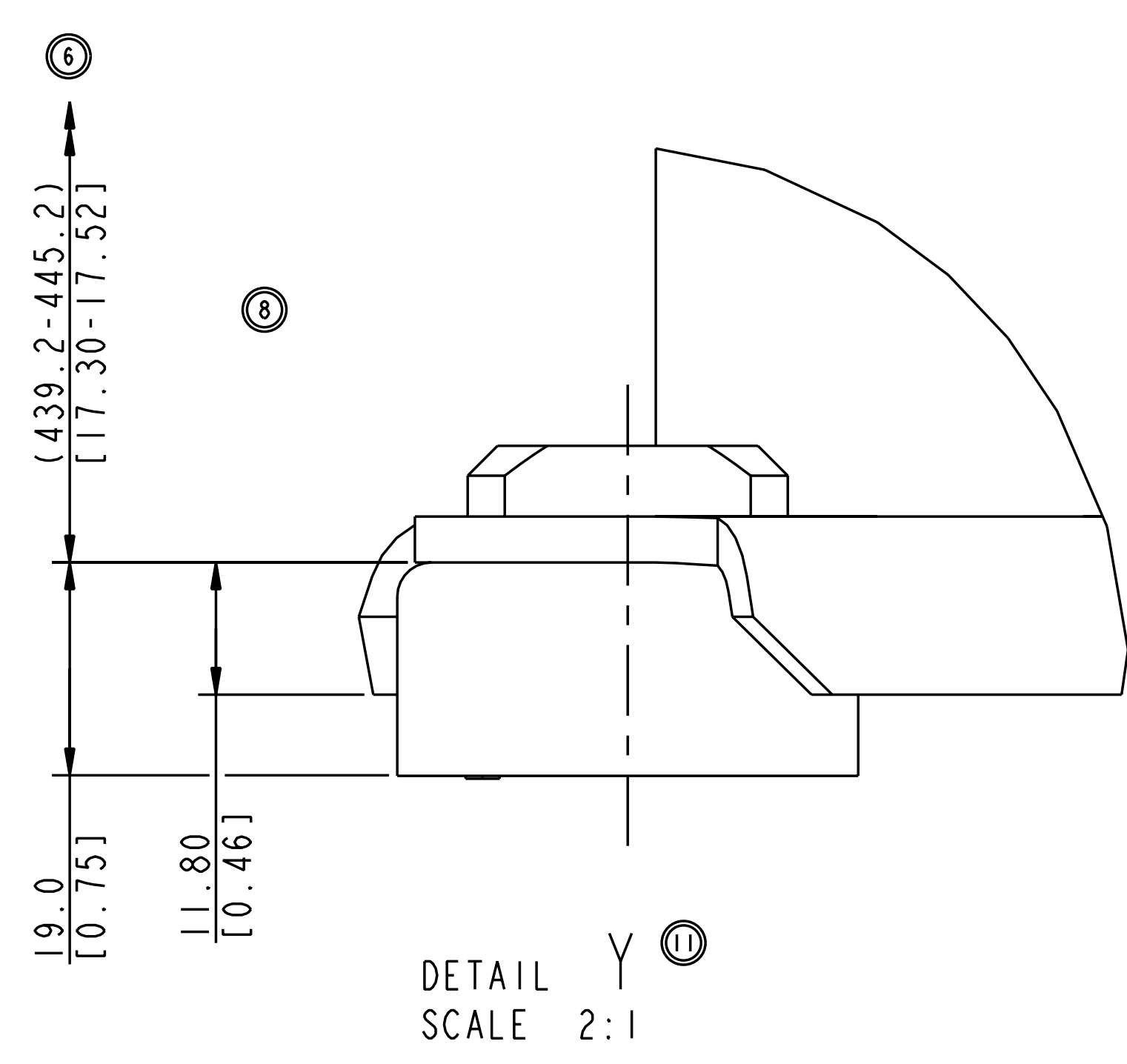
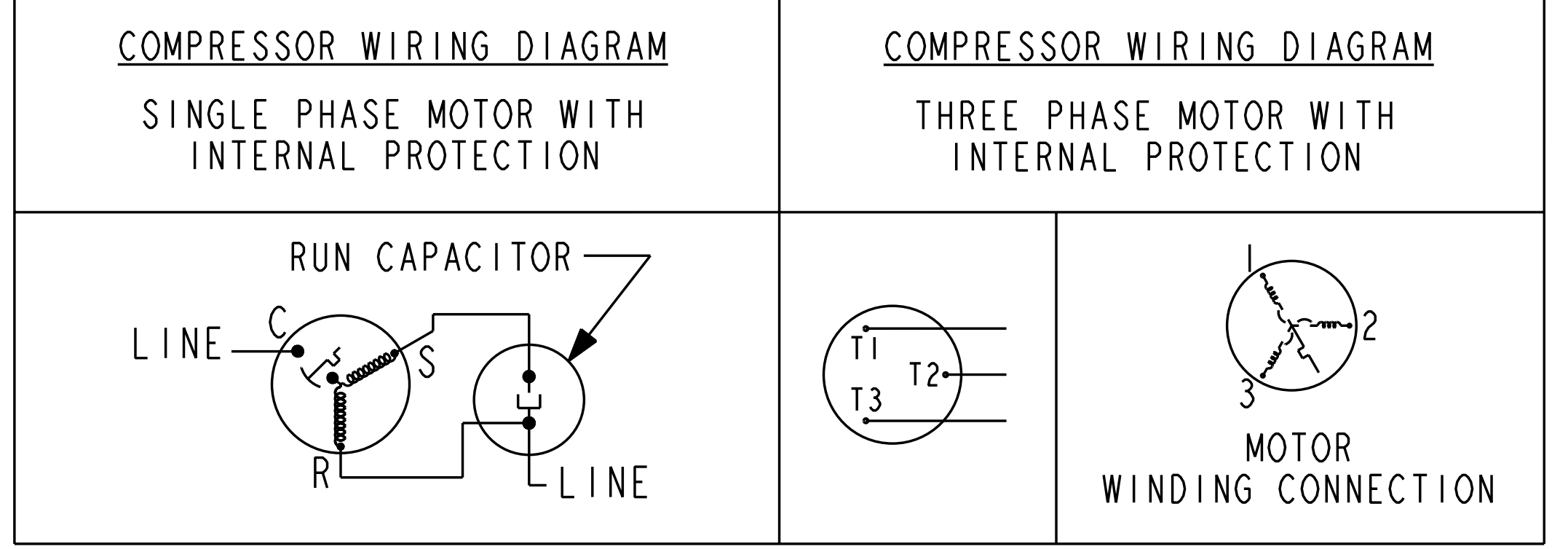

INTERPRET PER ASME Y14.5M-1994 AND EMERSON CLIMATE TECHNOLOGIES, INC. DESIGN STANDARDS DS2002 DO NOT SCALE DRAWING  
 THIRD ANGLE PROJECTION  
 CRITICAL PRODUCT CHARACTERISTIC  
 UNLESS OTHERWISE SPECIFIED DIMENSIONS ARE MILLIMETER OR (INCH)  
 TOLERANCES:  
 1-PLACE ±  
 2-PLACE ±  
 ANGULAR ± N/A

ECN	REV. NO.	DESCRIPTION	DATE	BY	CHKD	APPR
ECN006047	11	REVISED DIMENSIONS	05-29-12	PPJ	MA	KJR
ECN001208	10	REPLACED SPACER MOUNTING ASSM WAS: 527-0212-00	08-06-08	PSD	EC	KJR
ECN000599	9	ADDED ZP54K3E-TF7	04-24-08	PBM	EC	KJR
ECN000418	8	ADDED ZP61KCE-TF7	02-25-08	SVK	EC	KJR
ECN000446	7	REPLACED SPACER MOUNTING ASSM WAS: 527-0205-00	01-29-08	SVK	EC	KJR
ECN000769	6	CENTERED DIMENSION Ø17.45 TO PIN CIRCLE	10-29-07	MPK	EC	KJR
ECN000244	5	ADDED ZP83KCE-TF7	09-20-07	TDS	EC	KJR
ECN000440	4	ADDED ZP72KCE-TF5; ADDED CPC	08-14-07	TDS	EC	KJR
32-0606-114	3	MOUNTING KIT WAS 527-0116-00	08-26-06	TM	EC	RST
32-1205-049	2	ADDED ZPD72KCE-TF7	02-17-06	XO	BL	WG
32-0405-050	1	REVISED TO SINGLE PIECE LOWER COVER	12-13-05	XO	EC	RST
32-0405-050	0	RELEASED	11-13-05	TM	EC	RST

TITLE	DATE	SCALE	DATE FORMAT	DRAWING NUMBER	SHEET 1 OF 1	DWG SIZE
REF DWG-WELD COMP ASSM	11-13-05	3:4	MM-DD-YY	497-2858-00		5