

THREAD	TORQUE REQUIREMENTS	
1-3/4"-12 UN	1500-1590 IN LBS	170-180 Nm
M10	398-487 IN LBS	45-55 Nm
SIGHT GLASS	600-690 IN LBS	68-78 Nm

MODEL NUMBER	COMP "A"	COMP "B"	COMP "C"
ZRY930K	ZR310K	ZR310K	ZR310K
ZRY114M	ZR380K	ZR380K	ZR380K
ZPY115M	ZP385K	ZP385K	ZP385K
ZPY885K	ZP295K	ZP295K	ZP295K

SPECIFICATIONS	
ES NO.	DESCRIPTION
ES92-155	CONVERSION-METRIC

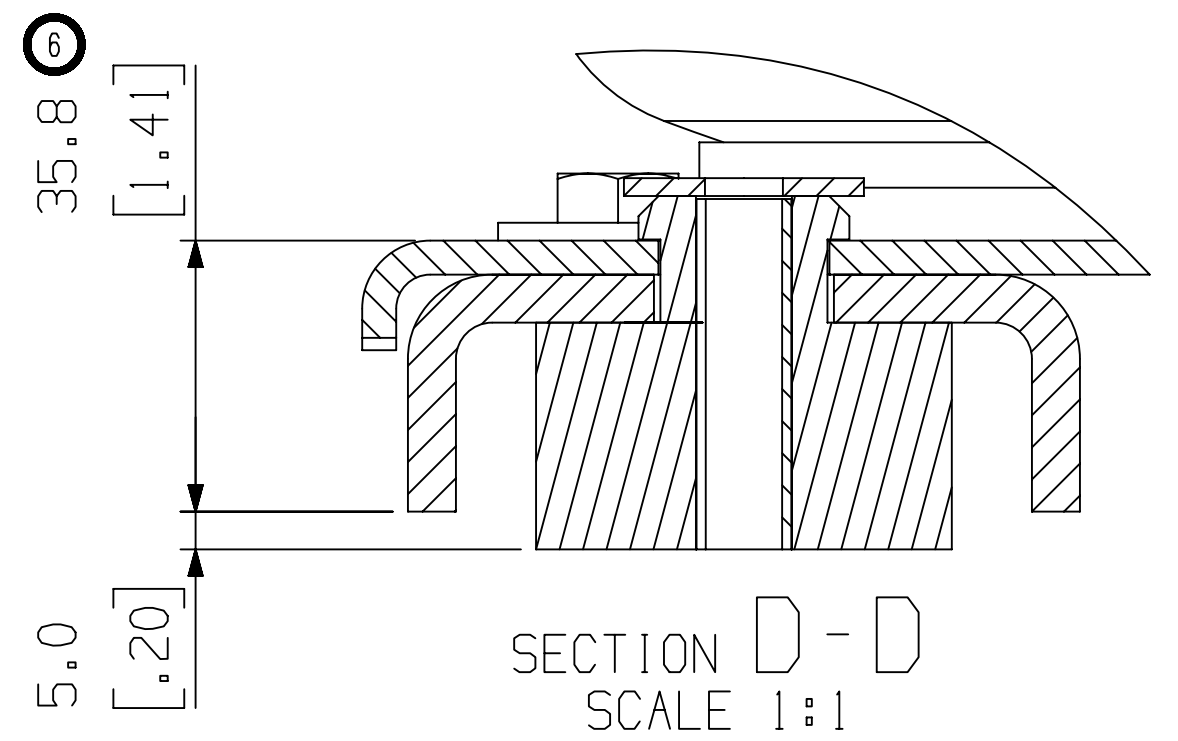
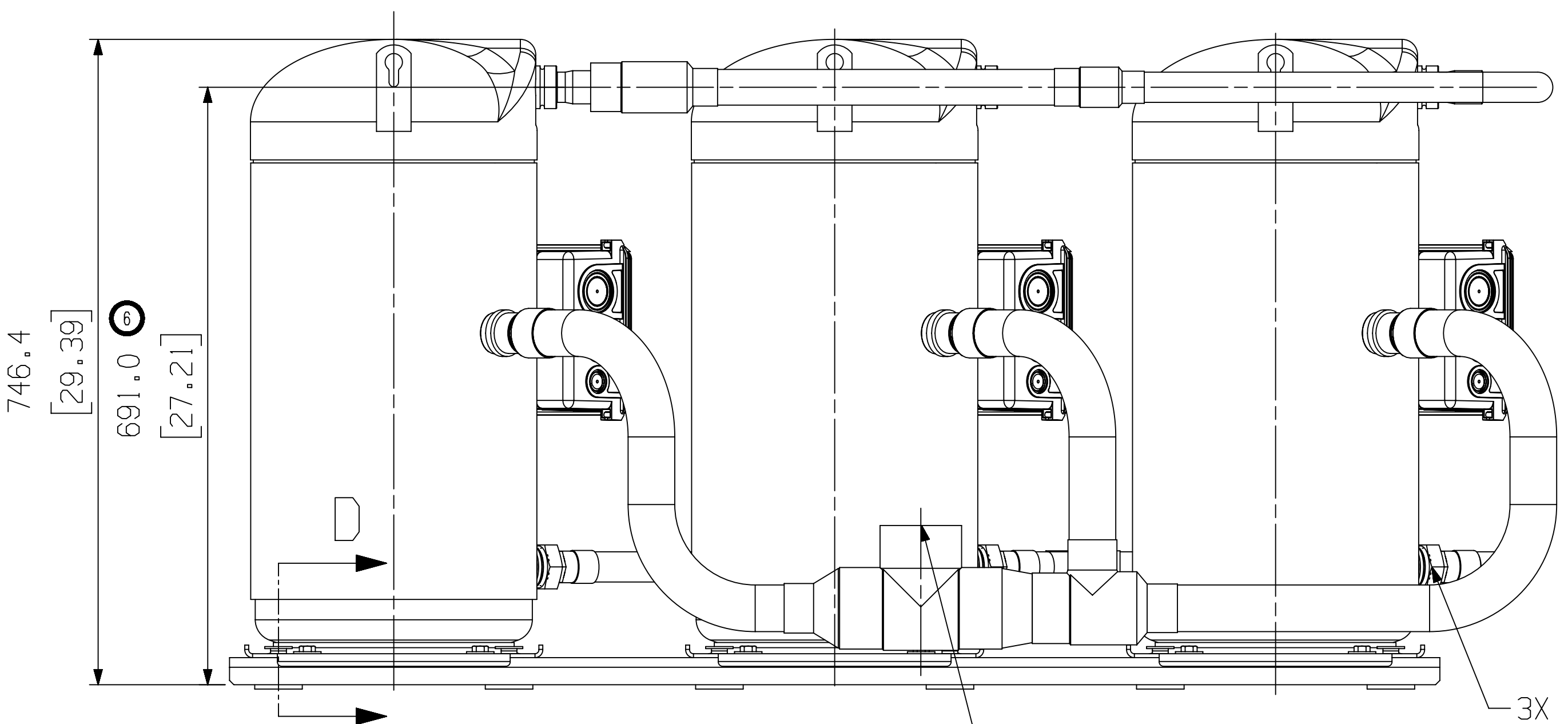
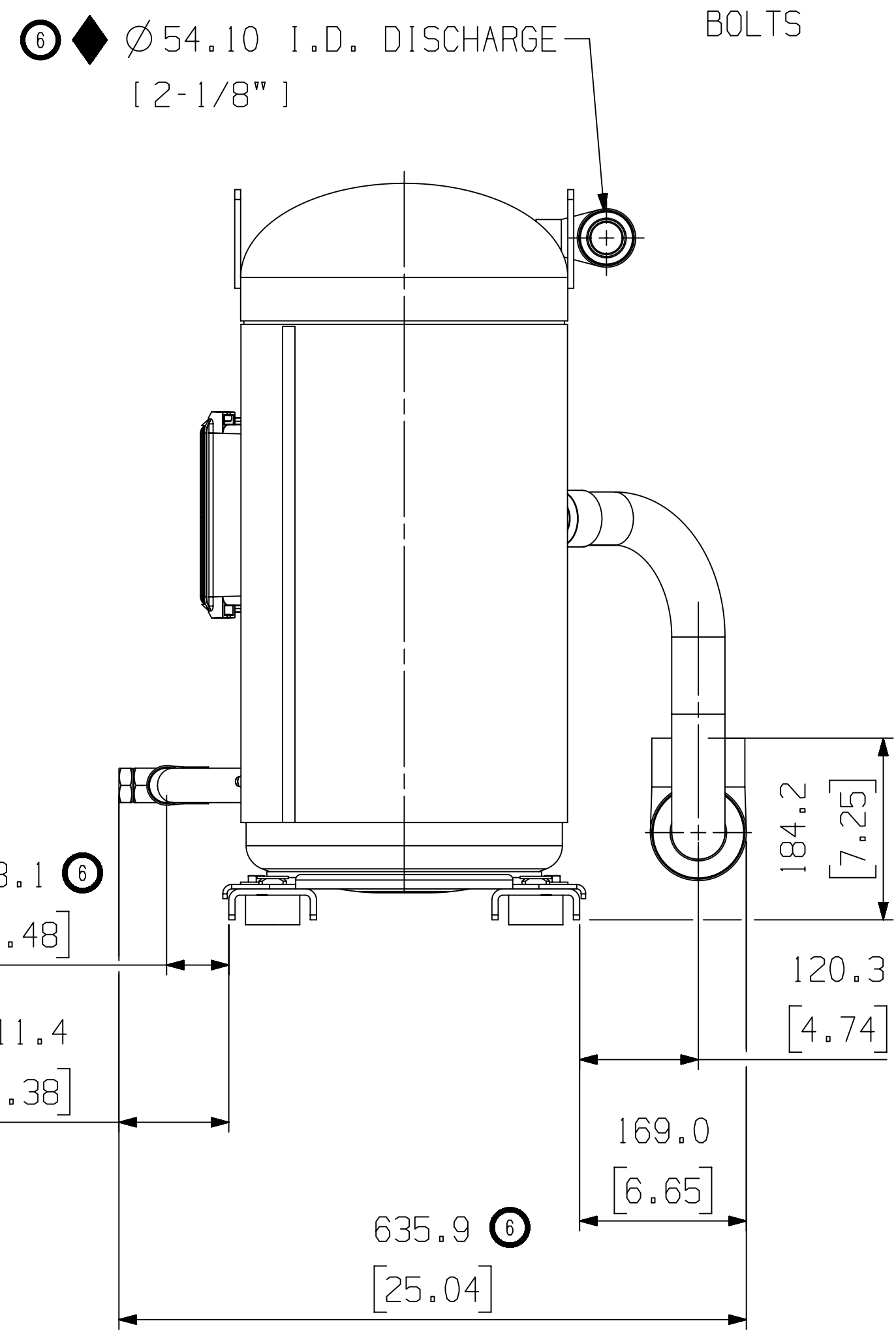
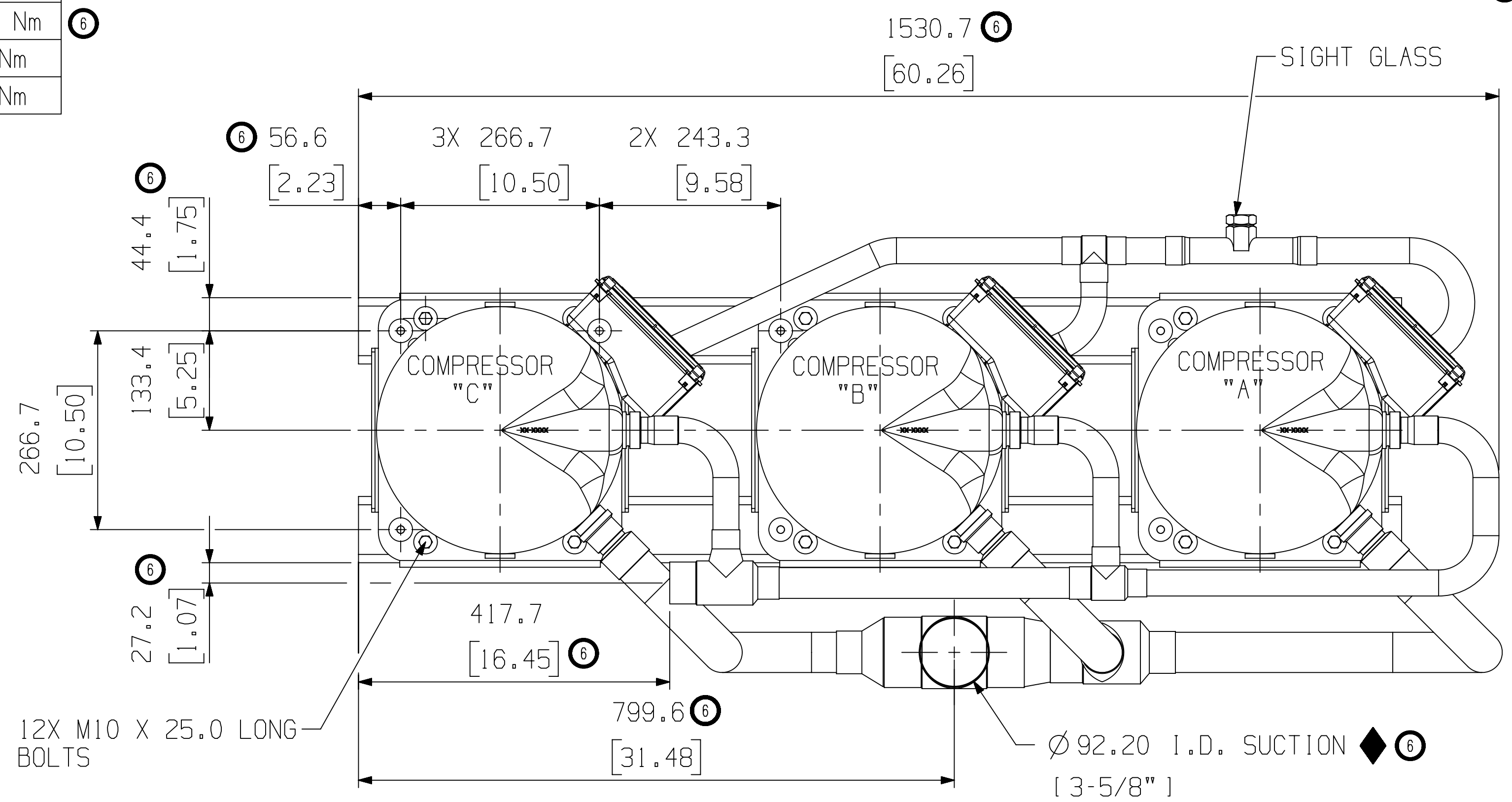

NOTES:

⑥  $\triangle$  ALL TOLERANCES ARE  $\pm 1.5$  [0.06] UNLESS OTHERWISE SPECIFIED.

DUE TO ACCUMULATED ASSEMBLY TOLERANCES THE LISTED COMPONENTS MAY VARY FROM THE MOUNTING HOLES AS SHOWN BELOW.

◆ ALL FITTINGS:  $\pm 3.0$  [0.12]

2. MOUNTING KIT: 527-0178-00

3. TUBE ENDS MUST BE PLUGGED.

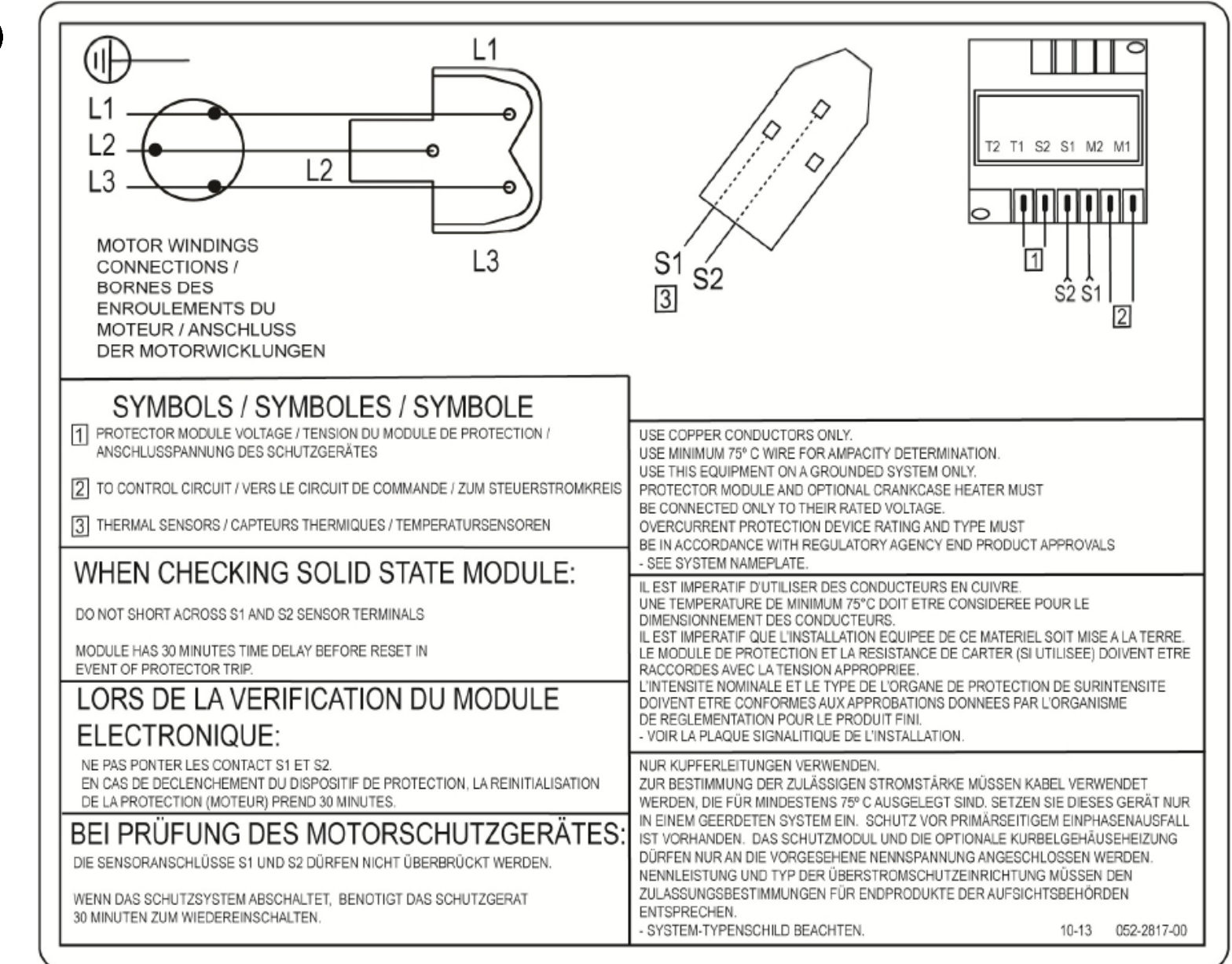

ECN101718	6	REDRAWN WITH CHANGES & SEE SHEET 2	01-03-19	SAS	PBM
32-0604-053	0	RELEASED	06-24-04	JLB	KK

ENG NOTICE NO.	REV. NO.	REVISIONS	DATE	BY	CHKD
22		THIS DRAWING AND INFORMATION CONTAINED HEREIN ARE THE EXCLUSIVE PROPERTY OF EMERSON CLIMATE TECHNOLOGIES, INC AND/OR ITS AFFILIATES (COLLECTIVELY "EMERSON") AND SHALL BE RETURNED UPON DEMAND AND SHALL NOT BE REPRODUCED IN WHOLE OR IN PART, DISCLOSED TO ANYONE ELSE OR USED, WITHOUT THE WRITTEN CONSENT OF EMERSON.			
MATERIAL SPECIFICATION		DRAWN BY	SUPERSEDES DWG NO / REV NO		
N/A		SAS	497-0385-03 / 005		
TITLE		DATE	SCALE	DATE FORMAT:	
REF DWG-WELD COMP ASM		01-03-19	1:5	MM-DD-YY	
		DRAWING NUMBER	SHEET 1 OF 2	DWG	
		497-0385-03		4	
				SIZE	

**EMERSON**  
**Copeland**

INTERPRET PER ASME Y14.5M-1994 AND EMERSON DESIGN STANDARDS DS2002

DO NOT SCALE DRAWING

CRITICAL PRODUCT CHARACTERISTICS

UNLESS OTHERWISE SPECIFIED DIMENSIONS ARE MILLIMETER OR ( INCH )

TOLERANCES:  
1-PLACE: ± N/A  
2-PLACE: ± N/A  
ANGULAR: ± N/A

①

© COPYRIGHT EMERSON - CONFIDENTIAL



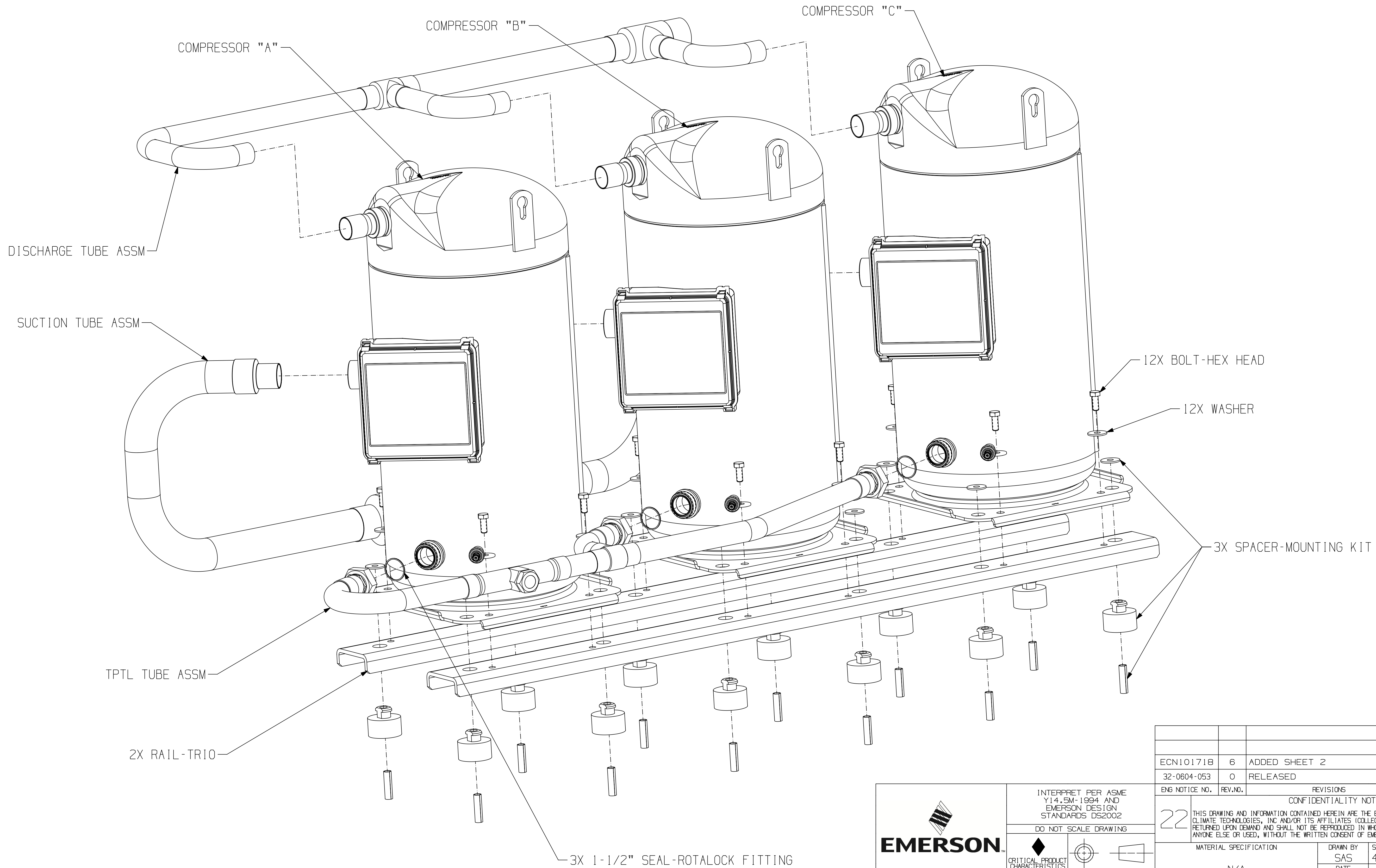

ECN101718	6	ADDED SHEET 2	01-03-19	SAS	PBM
32-0604-053	0	RELEASED	06-24-04	JLB	KK
ENG NOTICE NO.	REV.NO.	REVISIONS	DATE	BY	CHKD
22		CONFIDENTIALITY NOTICE			
THIS DRAWING AND INFORMATION CONTAINED HEREIN ARE THE EXCLUSIVE PROPERTY OF EMERSON CLIMATE TECHNOLOGIES, INC AND/OR ITS AFFILIATES (COLLECTIVELY "EMERSON") AND SHALL BE RETURNED UPON DEMAND AND SHALL NOT BE REPRODUCED IN WHOLE OR IN PART, DISCLOSED TO ANYONE ELSE OR USED, WITHOUT THE WRITTEN CONSENT OF EMERSON.					
MATERIAL SPECIFICATION		DRAWN BY	SUPERSEDES DWG NO / REV NO	DATE FORMAT: MM-DD-YY	
N/A		SAS	497-0385-03 / 005	MM-DD-YY	
		DATE	SCALE	DATE	
		01-03-19	1:3	MM-DD-YY	
TITLE			DRAWING NUMBER	SHEET 2 OF 2 DWG	
REF DWG-WELD COMP ASM			497-0385-03	4	
			SIZE		

**EMERSON**  
**Copeland**

INTERPRET PER ASME Y14.5M-1994 AND EMERSON DESIGN STANDARDS DS2002

DO NOT SCALE DRAWING

CRITICAL PRODUCT CHARACTERISTICS

UNLESS OTHERWISE SPECIFIED DIMENSIONS ARE MILLIMETER OR ( INCH )

TOLERANCES:  
1-PLACE ± N/A  
2-PLACE ± N/A  
ANGULAR ± N/A

© COPYRIGHT EMERSON - CONFIDENTIAL